

USER'S MANUAL

CM-500

SIGN MAKER

CAMM-1 PRO

by ROLAND DIGITAL GROUP

CM-400

CM-300

Thank you very much for purchasing the CM-500/400/300.

- To ensure correct and safe usage with a full understanding of this product's performance, please be sure to read through this manual completely and store it in a safe location.
- Unauthorized copying or transferral, in whole or in part, of this manual is prohibited.
- The contents of this operation manual and the specifications of this product are subject to change without notice.
- The operation manual and the product have been prepared and tested as much as possible. If you find any misprint or error, please inform us.

For the USA

FEDERAL COMMUNICATIONS COMMISSION RADIO FREQUENCY INTERFERENCE STATEMENT

This equipment has been tested and found to comply with the limits for a Class A digital device, pursuant to Part 15 of the FCC Rules.

These limits are designed to provide reasonable protection against harmful interference when the equipment is operated in a commercial environment.

This equipment generates, uses, and can radiate radio frequency energy and, if not installed and used in accordance with the instruction manual, may cause harmful interference to radio communications.

Operation of this equipment in a residential area is likely to cause harmful interference in which case the user will be required to correct the interference at his own expense.

Unauthorized changes or modification to this system can void the users authority to operate this equipment.

The I/O cables between this equipment and the computing device must be shielded.

NOTICE

Grounding Instructions

Do not modify the plug provided - if it will not fit the outlet, have the proper outlet installed by a qualified electrician.

Check with qualified electrician or service personnel if the grounding instructions are not completely understood, or if in doubt as to whether the tool is properly grounded.

Use only 3-wire extension cords that have 3-prong grounding plugs and 3-pole receptacles that accept the tool's plug.

Repair or replace damaged or worn out cord immediately.

Operating Instructions

KEEP WORK AREA CLEAN. Cluttered areas and benches invites accidents.

DON'T USE IN DANGEROUS ENVIRONMENT. Don't use power tools in damp or wet locations, or expose them to rain. Keep work area well lighted.

DISCONNECT TOOLS before servicing; when changing accessories, such as blades, bits, cutters, and like.

REDUCE THE RISK OF UNINTENTIONAL STARTING. Make sure the switch is in off position before plugging in.

USE RECOMMENDED ACCESSORIES. Consult the owner's manual for recommended accessories. The use of improper accessories may cause risk of injury to persons.

NEVER LEAVE TOOL RUNNING UNATTENDED.
TURN POWER OFF. Don't leave tool until it comes to a complete stop.

For Canada

CLASS A NOTICE

This Class A digital apparatus meets all requirements of the Canadian Interference-Causing Equipment Regulations.

CLASSE A AVIS

Cet appareil numérique de la classe A respecte toutes les exigences du Règlement sur le matériel brouilleur du Canada.



ROLAND DG CORPORATION

1-6-4 Shinmiyakoda, Hamamatsu-shi, Shizuoka-ken, JAPAN 431-2103

MODEL NAME : See the MODEL given on the rating plate.

RELEVANT DIRECTIVE : EC MACHINERY DIRECTIVE (89/392/EEC)

EC LOW VOLTAGE DIRECTIVE (73/23/EEC)

EC ELECTROMAGNETIC COMPATIBILITY DIRECTIVE (89/336/EEC)

WARNING

This is a Class A product. In a domestic environment this product may cause radio interference in which case the user may be required to take adequate measures.

Table of Contents



To Ensure Safe Use	2
About the Labels Affixed to the Unit	5
1 Checking Supplied Items	7
2 Part Names and Functions	7
2-1 Front View	7
2-2 Rear View	8
2-3 Operation Panel	8
3 Setup	9
3-1 Setting Up and Connection	9
3-2 Turning on the Power	10
3-3 Selecting the Interface	11
3-4 About the Driver	11
4 Basic Operation	12
4-1 Installing a Blade	12
4-2 Loading the Material	13
● Loading Roll Material	15
● To Perform Lengthy Cutting	18
● Loading Flat Material (Standard-size Material, Cut Material, Etc.)	19
4-3 About the Cutting Area	20
4-4 Setting the Origin Point	20
4-5 Cutting Test (How to Adjust Pen Force and Blade Extension)	21
4-6 Downloading Cutting Data	24
4-7 Applying the Completed Cutout	25
4-8 When Cutting is Completed	26
5 Maintenance	27
5-1 Cleaning	27
5-2 How to Replace the Separating Knife	28
6 Using the Display Menus	29
7 Display Menus Flowchart	30
8 Display Menu Lists	32
9 About the Blades and Materials	37
10 Plotting on Paper Media	38
11 What to do if...	39
11-1 What to do if...	39
11-2 Error Messages	42
12 Instruction Support Chart	43
13 Character Sets	44
Specifications	45

Windows® is a registered trademark or trademark of Microsoft® Corporation in the United States and/or other countries.



Copyright © 1998 ROLAND DG CORPORATION

To Ensure Safe Use

About ⚠ WARNING and ⚠ CAUTION Notices

 WARNING	Used for instructions intended to alert the user to the risk of death or severe injury should the unit be used improperly.
 CAUTION	Used for instructions intended to alert the user to the risk of injury or material damage should the unit be used improperly. * Material damage refers to damage or other adverse effects caused with respect to the home and all its furnishings, as well to domestic animals or pets.

About the Symbols

	The ⚠ symbol alerts the user to important instructions or warnings. The specific meaning of the symbol is determined by the design contained within the triangle. The symbol at left means "danger of electrocution."
	The ⚡ symbol alerts the user to items that must never be carried out (are forbidden). The specific thing that must not be done is indicated by the design contained within the circle. The symbol at left means the unit must never be disassembled.
	The ● symbol alerts the user to things that must be carried out. The specific thing that must be done is indicated by the design contained within the circle. The symbol at left means the power-cord plug must be unplugged from the outlet.

⚠ WARNING



Do not disassemble, repair, or modify.

Doing so may lead to fire or abnormal operation resulting in injury.



Do not use with any electrical power supply that does not meet the ratings displayed on the unit.

Use with any other power supply may lead to fire or electrocution.



Ground the unit with the ground wire.

Failure to do so may result in risk of electrical shock in the even of a mechanical problem



Do not use while in an abnormal state (i.e., emitting smoke, burning odor, unusual noise, or the like).

Doing so may result in fire or electrical shock.
 Immediately switch off the power, unplug the power cord from the electrical outlet, and contact your authorized Roland dealer or service center.

CAUTION



Do not attempt to unplug the power cord with wet hands.

Doing so may result in electrical shock.

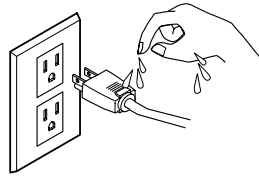

Do not use with a damaged power cord or plug, or with a loose electrical outlet.

Use with any other power supply may lead to fire or electrocution.

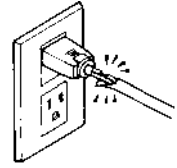

When unplugging the electrical power cord from a power outlet, grasp the plug, not the cord.

Unplugging by pulling the cord may damage it, leading to fire or electrocution.

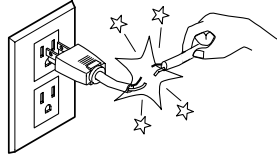

When not in use for prolonged periods, unplug the power cord from the electrical outlet.

Failure to do so may result in danger of shock, electrocution, or fire due to deterioration of the electrical insulation.

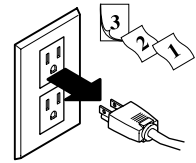

Do not injure or modify the electrical power cord, nor subject it to excessive bends, twists, pulls, binding, or pinching, nor place any object of weight on it.

Doing so may damage the electrical power cord, leading to electrocution or fire.

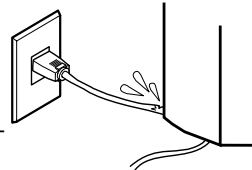

Unpacking, installing, or relocating the unit are operations which must be carried out by two or more persons holding the unit at its bottom surface on the left and right sides.

Failure to do so may result in dropping the unit, leading to injury.

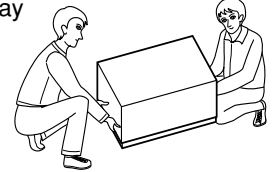

Do not allow liquids, metal objects or flammables inside the machine.

Such materials can cause fire.

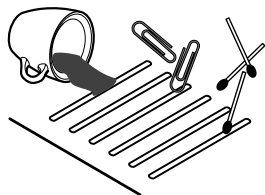

Do not place hands near the platen while in operation.

Doing so may result in injury.

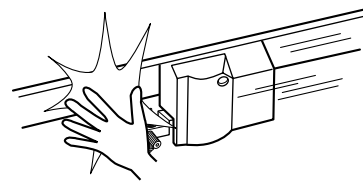

Do not touch the tip of the blade with your fingers.

Doing so may result in injury.



Install in a level and stable location.

Otherwise the unit may tip over and cause injury.

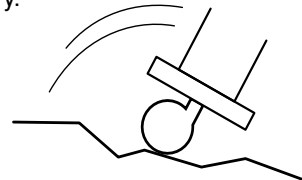

Make sure the power to the unit is off before attempting to replace the separating knife.

Doing so may result in injury.

CAUTION



Use care to avoid pinching the fingers when placing the unit on the stand.

Doing so may result in injury.

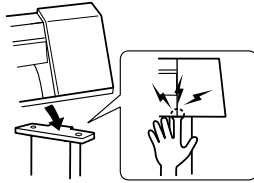

Use the joining screws to secure the unit to the stand.

Failure to do so may result in falling of the unit, leading to injury.

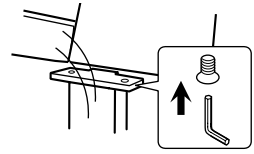

Roll material must be placed at a predetermined shaft position.

Failure to do so may result in falling of the roll, leading to injury.

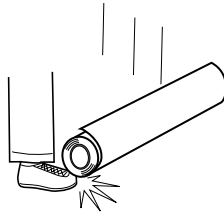

Release the caster locks for the stand before attempting to move.

Otherwise the unit may tip over and cause injury.

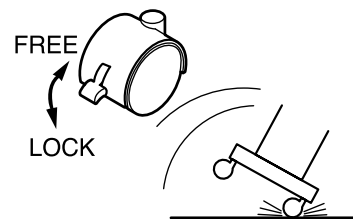

About the Labels Affixed to the Unit

These labels are affixed to the body of this product.

The following figure describes the location and content of these messages.

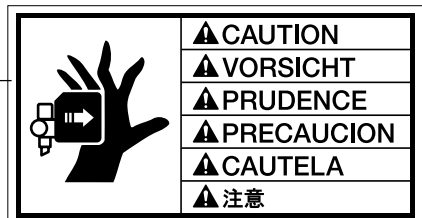
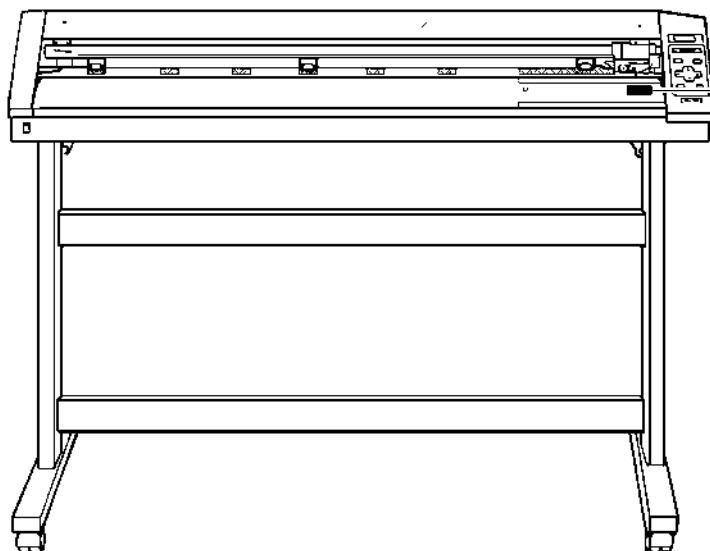

Do not place hands near the platen while in operation.

N'approchez pas vos mains du plateau de travail quand le chariot est en mouvement.

Model name
Rating label

Use a rated power supply.

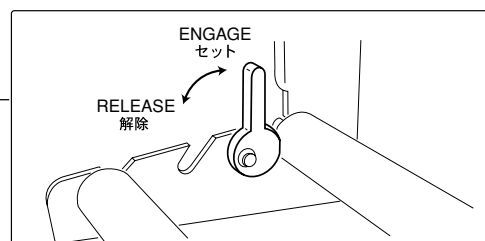
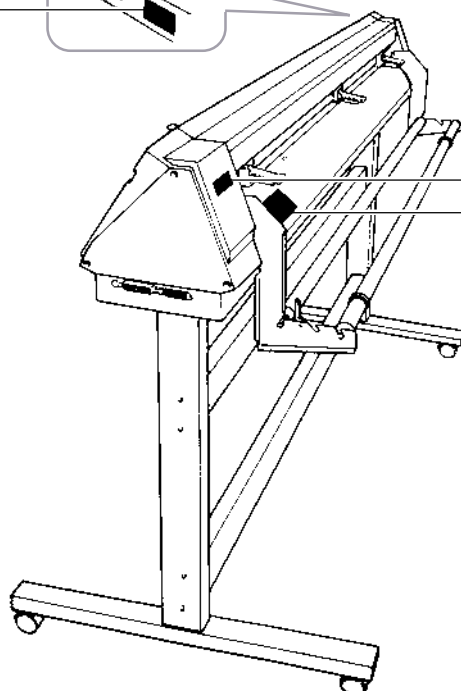
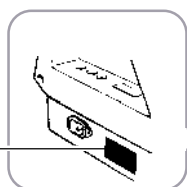

NOTICE

Use the brake when you want to load a piece of material. When performing material feed or cutting, be sure to release the brake.

Attempting to perform material feed or cutting without releasing the brake may make normal feed impossible and cause the material to slip.

ご注意

- ・ブレーキはシートをセットするときに使用してください。
- ・シート送りやカッティングを行うときには、必ずブレーキを解除してください。
- ・ブレーキを解除しないでシート送りやカッティングを行うと、正常なシート送りができなくなり、シートずれを起こすことがあります。

In addition to the **⚠ WARNING** and **⚠ CAUTION** symbols, the symbols shown below are also used.

NOTICE : Indicates information to prevent machine breakdown or malfunction and ensure correct use.











: Indicates a handy tip or advice regarding use.

- MEMO -

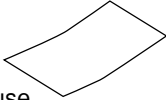
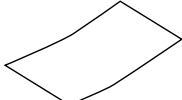
1 Checking Supplied Items

Check the following to make sure that you received all the items that were shipped along with the unit.

 Power Cord: 1	 Blade Holder (XD-CH2)	 Blade (ZEC-U5025)	 Test use Water Based Fiber Tipped Pen
 Test-use Application Tape	 Material for Test Cuts	 Tweezers (for handling material)	 Replacement blade for separating knife
 User's Manual	 CAMM-1 DRIVER for windows® 95		

2 Part Names and Functions

* The figure shows the CM-500 installed with the PNS-500 special stand.

2-1 Front View

Front Cover
Opening the cover during operation pauses the machine.

Movable Pinch Roller (middle)
This is used when cutting materials with a width of 762 mm (30") or more. At this time, it is set at the center of the left and right pinch rollers or above the grit roller near the center.

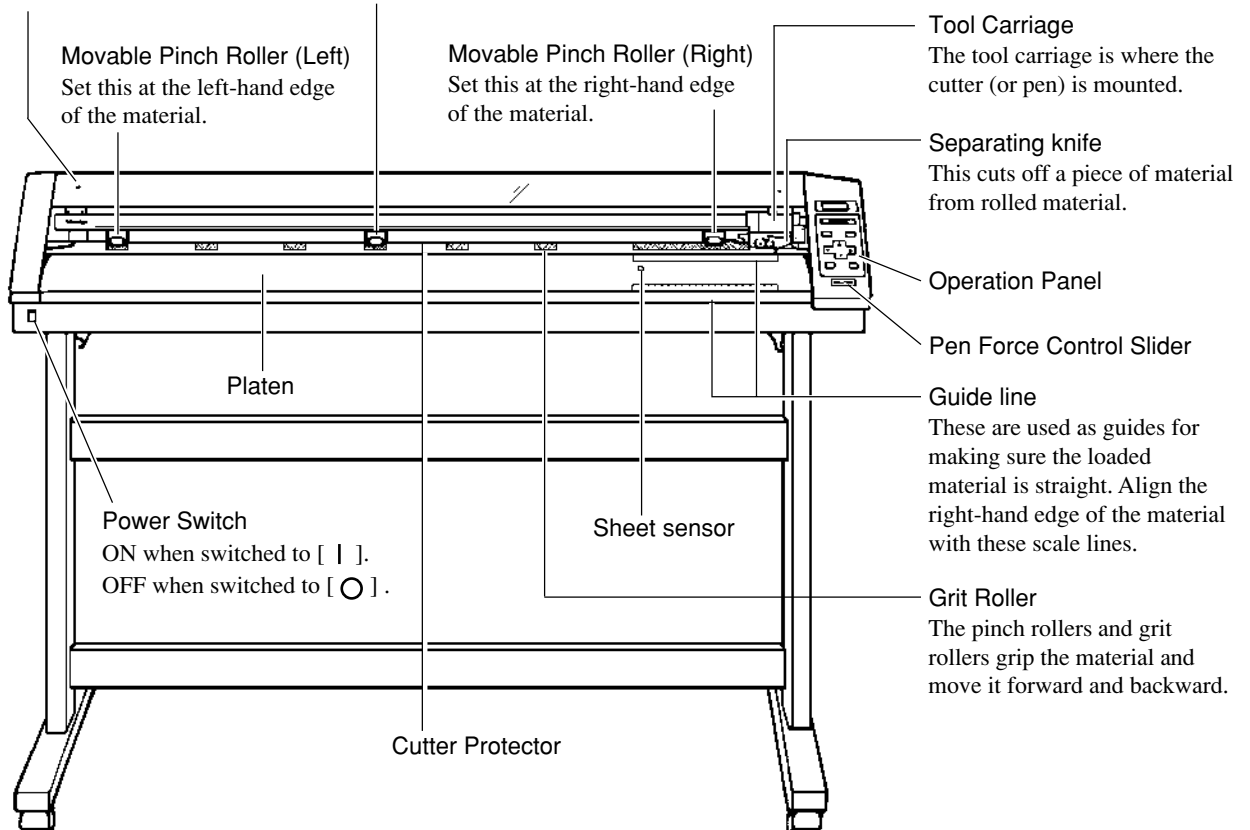

2-2 Rear View

Sheet Loading Lever
These raise and lower the pinch rollers.

Parallel (Centronics) Connector
This is for connecting a computer with a parallel (printer) cable.

Serial (RS-232C) Connector
This is for connecting a computer with a serial (RS-232C) cable.

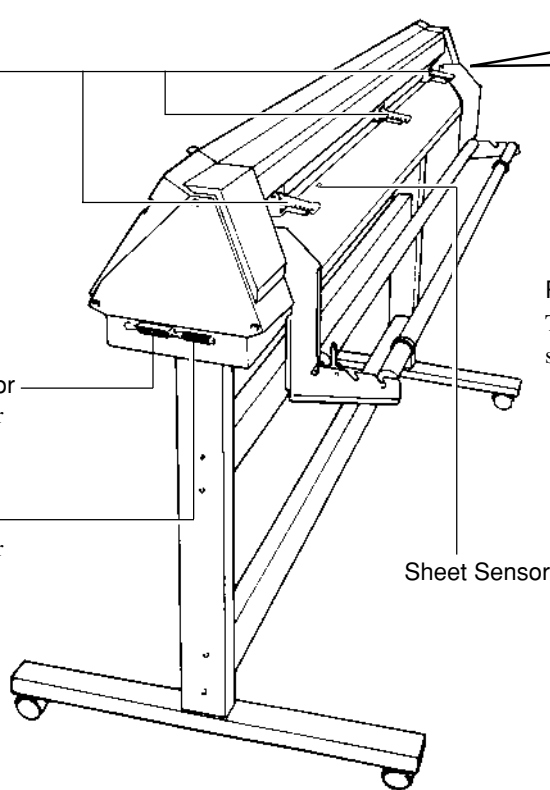

Power Connector [AC IN]
This connector accepts standard AC power cord.

Tray
Use this to store blades or pens.

2-3 Operation Panel

Blinking Cursor
Used to select the desired item from the menu.
Use the and keys to select items, and the and keys to change values.

Display
Provides menu display, configuration preferences, coordinates, as well as error messages for troubleshooting.

MENU Key
Employed to select among the available menus, or to cancel the making of a setting at a particular menu.

ENTER Key
Press to enter into a subroutine of the item selected using the cursor keys or to confirm (save) the value set in configuration.

PAUSE LED
This lights up when the CM-500/400/300 is paused.

PAUSE Key
When pressed once, this temporarily halts cutting in progress. Pressing this key again releases the paused state.

SHEET CUT Key
This is use to sever an already-cut piece of material from the rolled material.

Power LED
This lights up when the power is switched on.

SETUP LED
This lights up when the SETUP key is pressed. Cutting can be performed when this is lit.

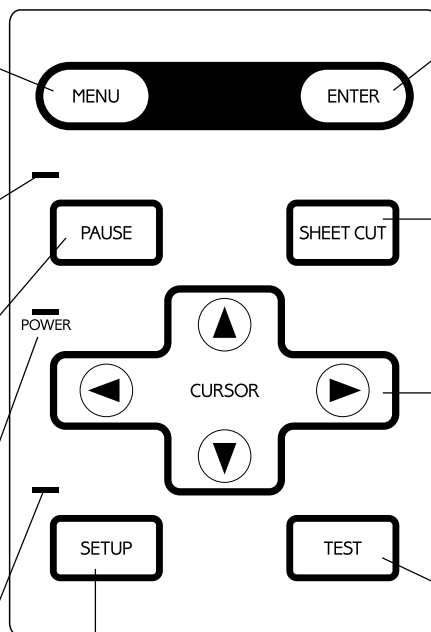
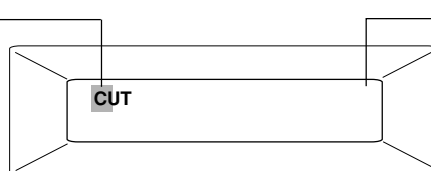

CURSOR Keys
Used to move the blinking cursor. The and keys are also used to move the material, and the and keys are used to move the tool carriage.

TEST Key
Pressed to execute a cutting test (Use to confirm material specifications as well as cutting speed, blade force, and blade compensation).

SETUP Key
Pressing this to detect width of the loaded material and enable the unit for cutting.

3 Setup

3-1 Setting Up and Connection

⚠️ WARNING



Ground the unit with the ground wire.

Failure to do so may result in risk of electrical shock in the even of a mechanical problem



Do not use with any electrical power supply that does not meet the ratings displayed on the unit.

Use with any other power supply may lead to fire or electrocution.

⚠️ CAUTION



Install on a stable surface.

Failure to do so may result in falling of the unit, leading to injury.

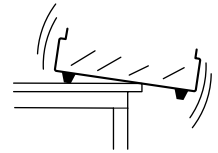

NOTICE

Never install this unit in any of the following situations, as it could result in damage:

Places where the installation surface is unstable or not level.

Places with excessive electrical noise.

Places with excessive humidity or dust.

Places with poor ventilation, because the CM-500/400/300 generates considerable heat during operation.

Places with excessive vibration.

Connect the cable to either the parallel or the serial port. Be sure that the power to both the computer and the main unit is switched off when connecting the cable.

Securely connect the power cord, computer I/O cable and so on so that they will not be unplugged and cause failure during operation. Doing so may lead to faulty operation or breakdown.

Setting Up

For an explanation of how to assemble the unit and the stand (PNS-500/400/300), refer to the "ASSEMBLY INSTRUCTIONS" included with the stand. When using the unit while mounted on a stand, be sure to ensure a sufficient amount of installation space for the unit. The required installation spaces for each model are listed below.

CM-500 : 1200 mm (47-1/4") high, 1700 mm (66-15/16") wide, and 900 mm (35-7/16") depth

CM-400 : 1200 mm (47-1/4") high, 1500 mm (59-1/16") wide, and 900 mm (35-7/16") depth

CM-300 : 1200 mm (47-1/4") high, 1250 mm (49-1/4") wide, and 900 mm (35-7/16") depth

The material moves while cutting is in progress. Objects which may obstruct material movement must not be placed within 60 cm (23-5/8") to the front or rear of the unit.

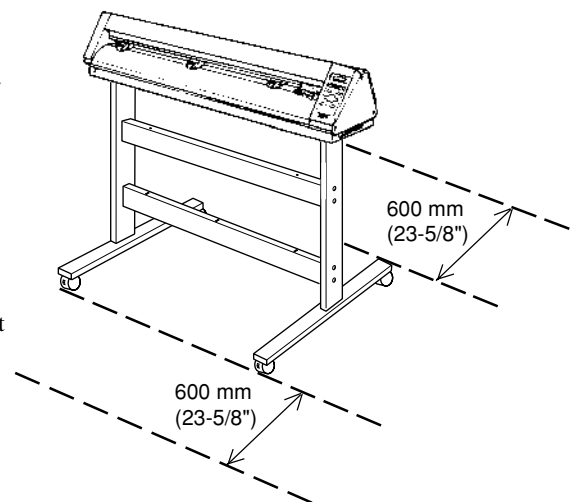

Connection

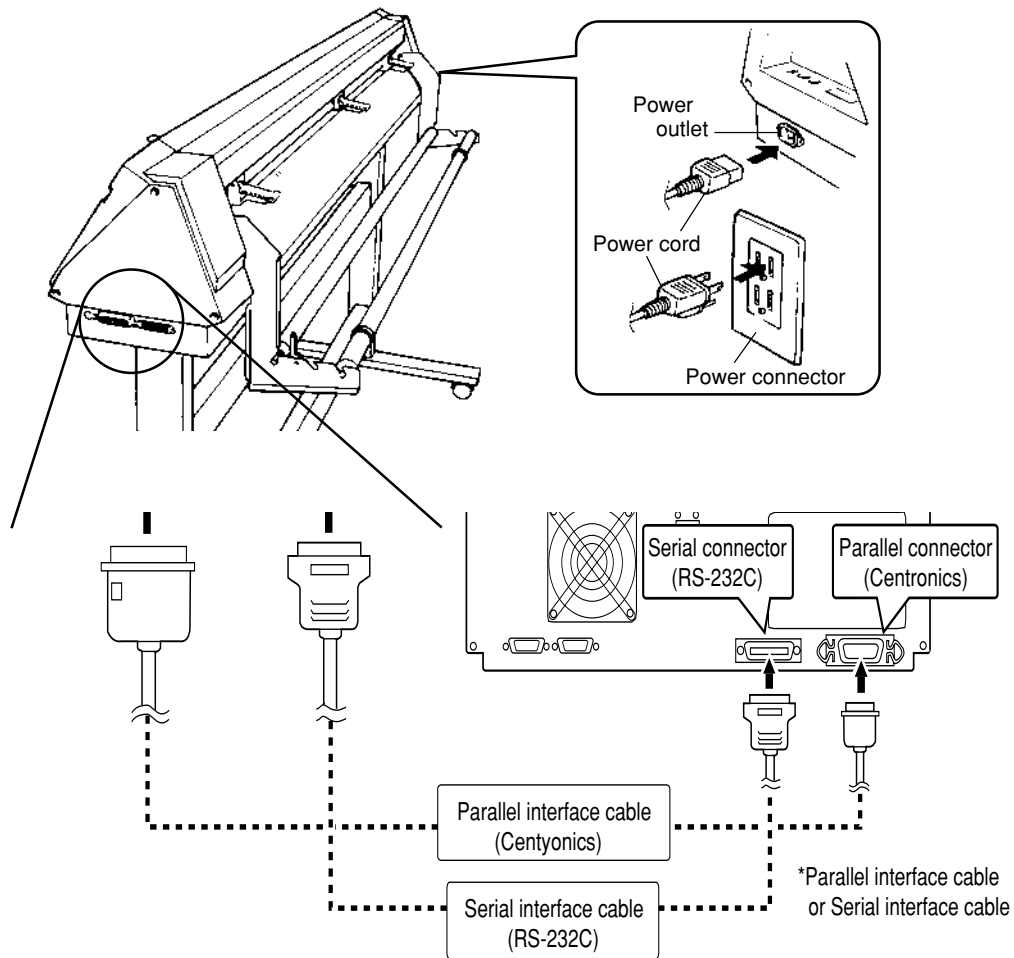

* Cables are available separately. One which you are sure matches the model of computer being used should be selected.

3-2 Turning on the Power

Use the switch at the front-left surface of the unit to turn on the power.

Press the side of the switch marked “-”.

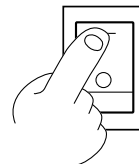

3-3 Selecting the Interface

Make sure the settings for the computer (driver) match the settings for the CM-500/400/300 interface. The selected interface type and communication parameters are stored in memory even after the power is switched off. To change the interface type or the communication parameters, configurations must be re-entered.

- 1** Close the front cover and press the **(MENU)** key. The menu shown at right appears on the display.
- 2** Use the **(◀)** and **(▶)** keys to move the blinking cursor to "SUBMENU" and press **(ENTER)** key.
- 3** Press the **(MENU)** key.
- 4** Use the **(◀)** and **(▶)** keys to move the blinking cursor to "I/O" and press **(ENTER)** key.
- 5** Select [Auto] and press the **(ENTER)** key.
 - * The CM-500/400/300 is equipped with an auto-interface function, and so when left set to "AUTO," it will automatically determine whether a parallel or serial connection is used.
- 6** Next, the menu at right appears.
 - If connected with a serial (RS-232C) cable, make the settings to match the communication parameters for the host computer or program. (Take a look at "7 Display Menus Flowchart.") If connected with a parallel (printer) cable, no settings are needed here.
 - * If the communication parameters for the computer and the CM-500/400/300 are not identical, the cutting data cannot be received correctly, which may result in faulty operation.

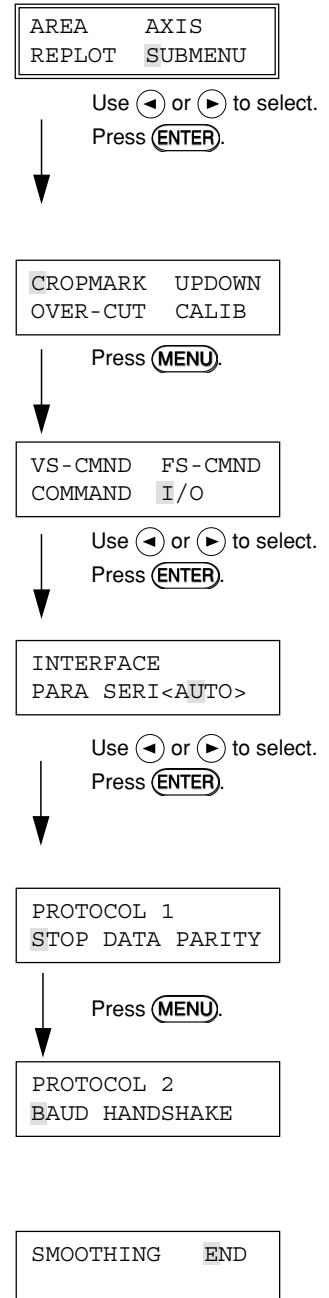

To leave a submenu, choose [END] in the menu shown at right, and press the **(ENTER)** key.

3-4 About the Driver

If you're using a program for Windows® 95, install the "CAMM-1 DRIVER for Windows® 95" included with the unit. For more information about the installation and setup of the CAMM-1 DRIVER for Windows® 95, please see the Readme.txt file. This file is found on the driver disk.

4 Basic Operation

4-1 Installing a Blade

⚠ CAUTION



Do not touch the tip of the blade with your fingers.

Doing so may result in injury, and the cutting performance of the blade will be impaired.



NOTICE

Be sure to support the tool mounting screw from below when installing the blade holder. Cutting quality may become poor if installed without supporting the screw in this way.

- 1** Insert a blade into the blade holder until it snaps into place with an audible click.

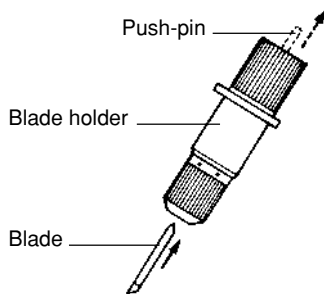

- 2** (1) Loosen the tool securing screw on the cutting carriage.
(2) Support the tool-securing screw from below and install the blade holder. Insert the blade holder until the collar is flush with the carriage.
(3) Tighten the tool securing screw until the blade holder is secured in place.

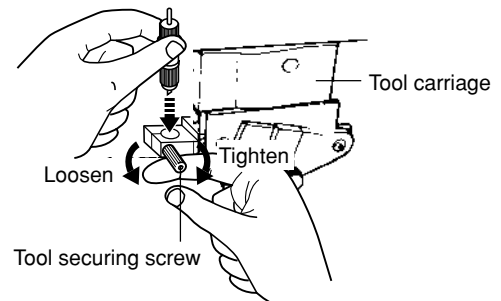

How to Set the Blade Offset

Set the blade offset for the installed blade. For more information about offset, see "9 About Blades and Material."

- (1) Close the front cover and press the **(MENU)** key until the message shown below appears.

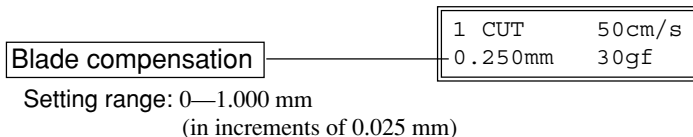

- (2) Use the **(◀)** and **(▶)** keys to enter the offset value, then press the **(ENTER)** key to accept the value.

Depending on the material in use, it may be necessary to adjust the tip of the blade. For more information, see "4-5 Cutting Test."

How to Set the Cutting Speed

(1) Close the front cover and press the **(MENU)** key until the message shown below appears.

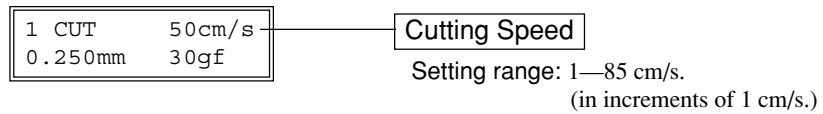

(2) Use the **(▲)** and **(▼)** keys to change the value, then press the **(ENTER)** key to accept the value.

(3) To adjust speed during tool-up time or to adjust cutting quality, press the **(▶)** key until the screen shown below appears. Use the **(▲)** and **(▼)** keys to change the value (or the selection) and enable the setting by pressing the **(ENTER)** key.

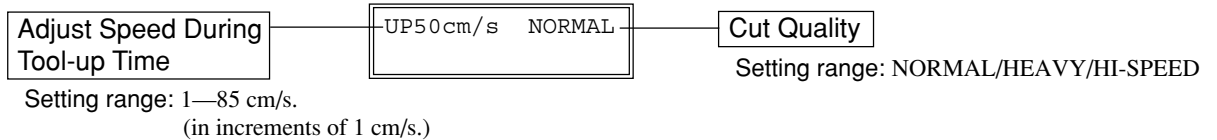

For more information, see "8 Display Menu Lists."

4-2 Loading the Material

⚠ CAUTION



Roll material must be placed at a predetermined shaft position.

Failure to do so may result in falling of the roll, leading to injury.

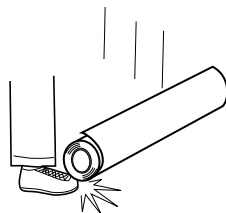

Width (horizontal dimension) and maximum cutting width

	Acceptable material widths		Maximum cutting area
CM-500	Min.90 mm (3-1/2")	Max.1372 mm (54")	1195 mm (47")
CM-400	Min.90 mm (3-1/2")	Max.1178 mm (46")	1000 mm (39")
CM-300	Min.50 mm (2") Max.915 mm (36") (50—540 mm (2"—21") , 582—915 mm (23"—36"))		737 mm (29")

There is no special restriction on length (vertical dimension), as long as it is 200 mm (7-1/4") or more.

This means that you can use either flat materials such as standard-size materials (ANSI, ISO, etc.) and cut materials, or roll materials.

The grit rollers (pinch rollers that secure the material) vary from one model to another, and settable ranges are determined for the left and right movable pinch rollers. See "Material Loading Position" on the next page.

Setting a pinch roller outside the allowed range causes an error message to appear.



Material Loading Position

- : Grit Roller
- : Movable Pinch Roller (Middle)
- : Movable Pinch Roller (Left)
- : Movable Pinch Roller (Right)

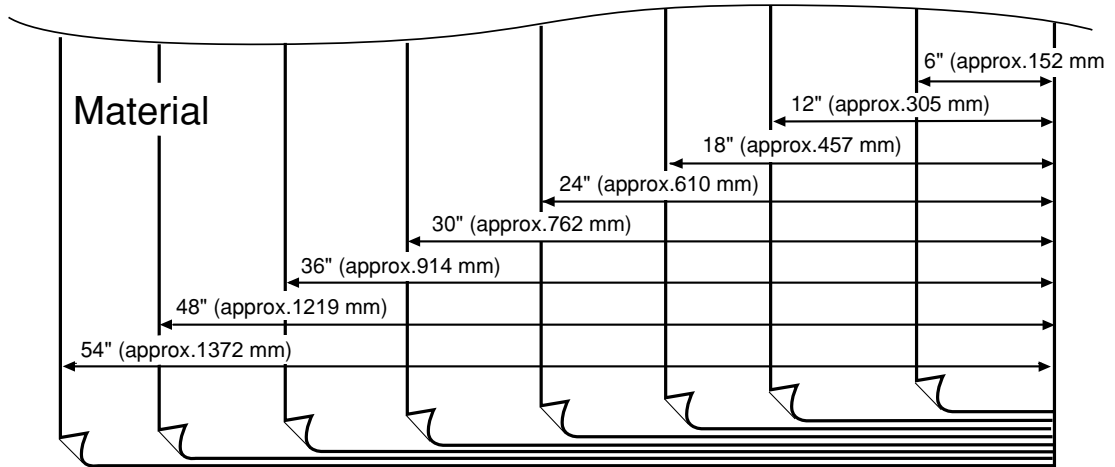

The right-hand movable pinch roller can be moved within this range. When loading material with a width other than one indicated above, move the right-hand movable pinch roller.

CM-500

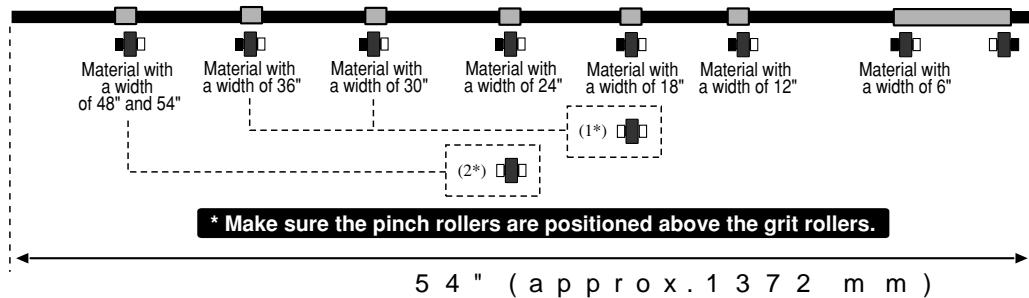

- (1*) Position of the pinch roller (middle) when using material with a width of 30" or 36"
- (2*) Position of the pinch roller (middle) when using material with a width of 48" or 54"

CM-400

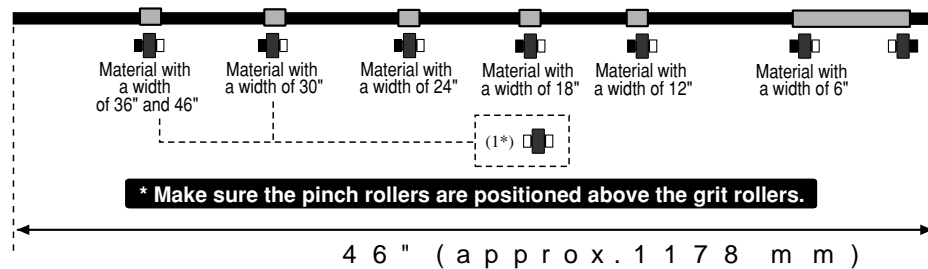

- (1*) Position of the pinch roller (middle) when using material with a width of 30" or more.

CM-300

- * Acceptable material widths
50—540 mm (2"—21") ,
582—915 mm (23"—36")

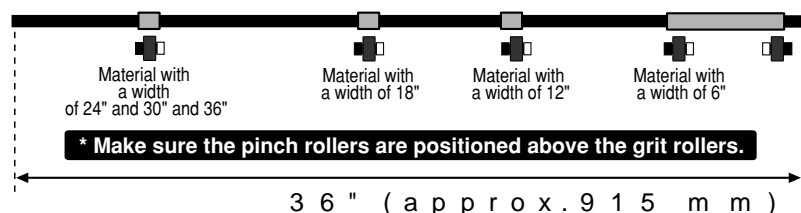

- * The CM-300 has no middle pinch roller.



To cut off a piece of material with the separating knife, load the media within the range shown below. Loading media outside this range may make it impossible to cut off the material with the separating knife.

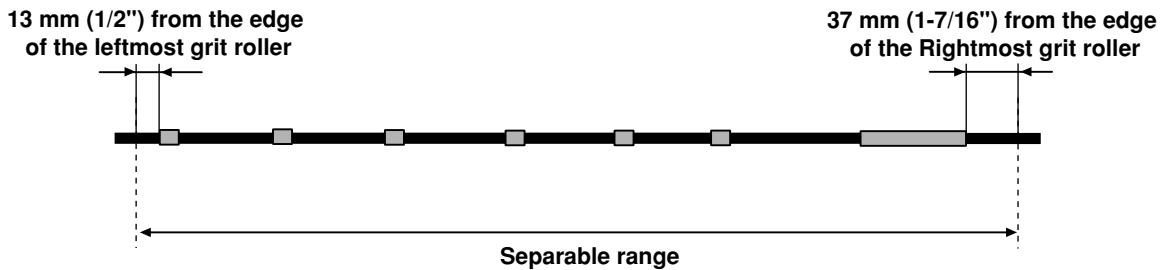

● Loading Roll Material

* When performing lengthy cutting of 1.5 m (60") or more, please refer to the section "●To Perform Lengthy Cutting" that follows this one.

For information on how to install the sheet hanger, shaft, brake, and stoppers, please refer to the assembly manual for the PNS-500/400/300 (the stand for the CM-500/400/300).

- 1 Mount the shaft at the location on the sheet hanger shown in the figure to match the outer diameter of the rolled material.

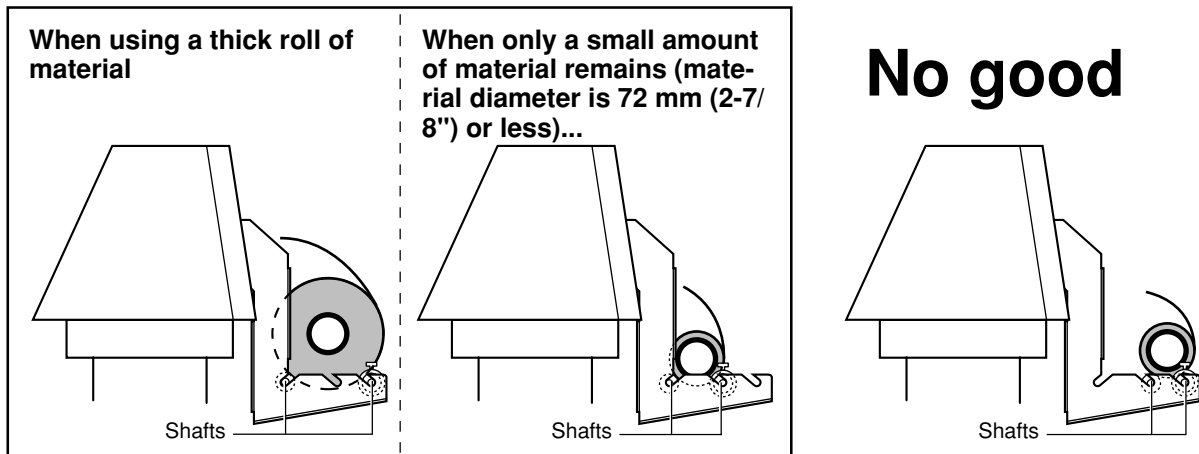

- 2 Place the rolled material on the shaft.

- 3 Lower the sheet loading levers and raise the pinch rollers. Pass the end of the material between the pinch rollers and the grit rollers so that it extends from the front of the unit.

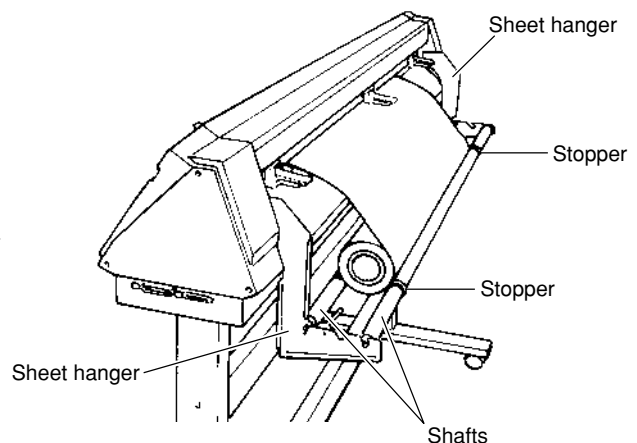

- 4** Position so that the left-hand edge of the material lies over any one of the grit rollers. Move the material from side to side and position so that the right-hand edge of the material lies over the rightmost grit roller.

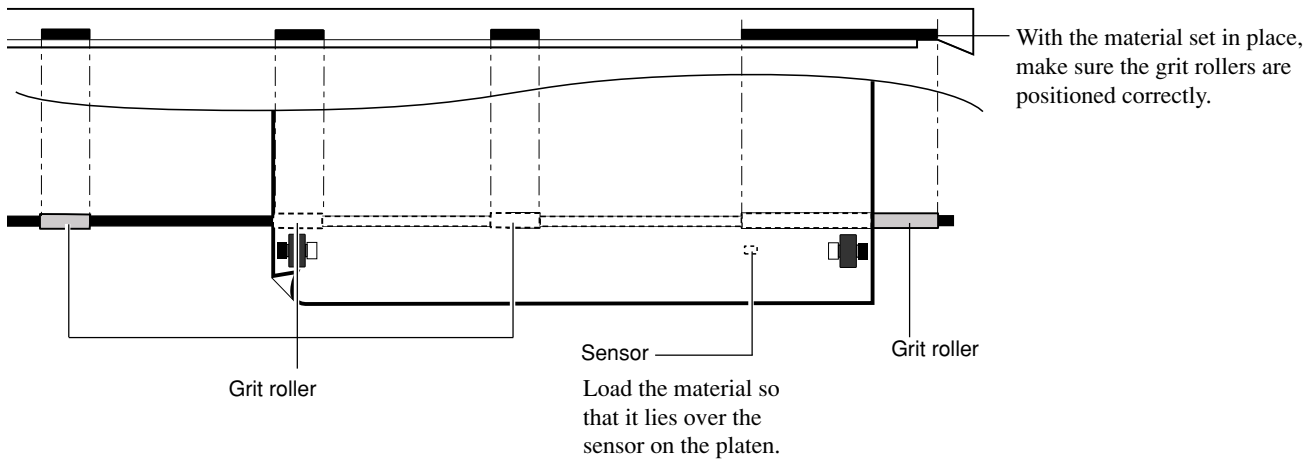

- 5** Load the material so that it lies straight and is aligned with the guide-line marks, then move the left and right pinch rollers so that they are above the grit rollers. Position the middle pinch roller over the grit roller that lies between the left- and right-hand pinch rollers. If a pinch roller does not move easily, it may help to grasp the corresponding sheet loading lever at the back of the unit and move it together with the pinch roller.

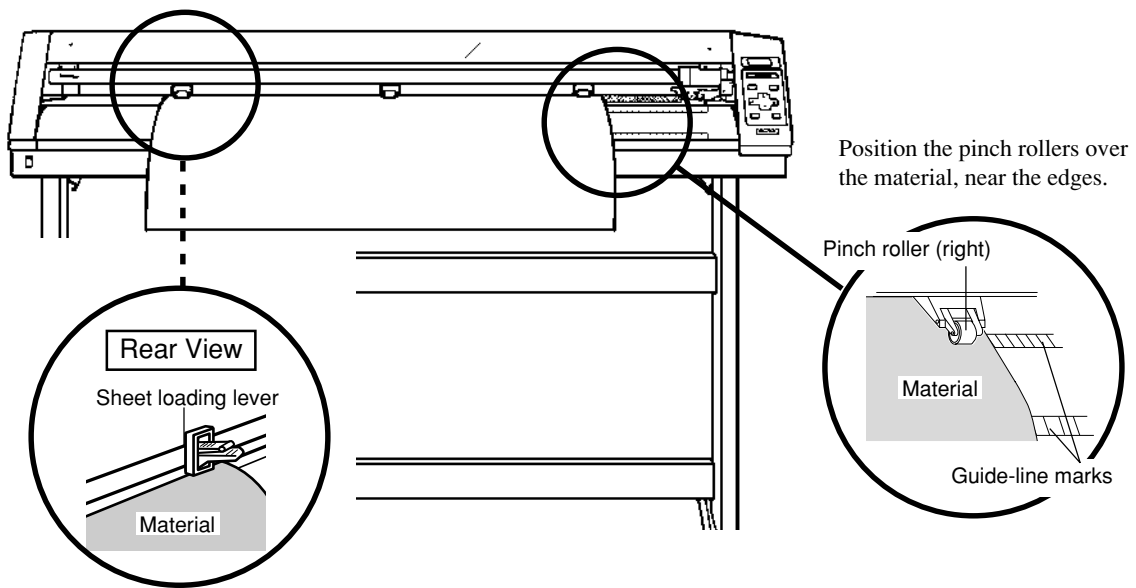

- 6** Lift the sheet loading lever. The pinch rollers are lowered and the material is secured in place. When using a material which is narrower than 762 mm (30"), do not lower the pinch rollers.

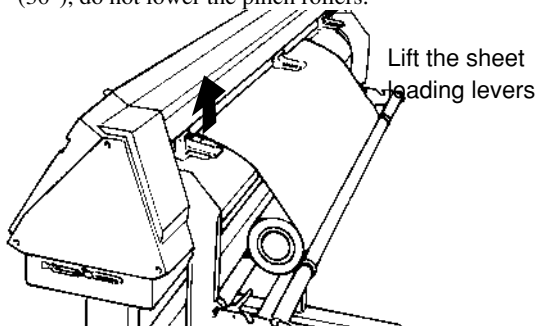

- 7** Position the stoppers so that they lightly touch the edges of the roll, and secure in place by tightening the screws.

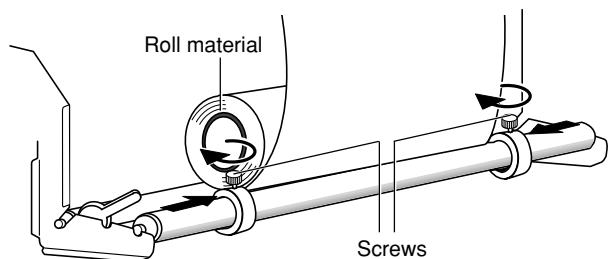

- 8** Follow steps 1 through 7 to secure the media in place, then pull out the required length for cutting from the roller.

- 9** Close the front cover.
Use the ◀ and ▶ keys to select [Roll], then press the **(ENTER)** key.
* If cutting is to be performed from the front edge of the material, select "EDGE."

Close the front cover

```
SELECT SHEET
ROLL EDGE PIECE
```

- 10** Press the **(SETUP)** key. The SETUP LED lights up, and the horizontal width of the material is detected and shown on the display.
* If "EDGE" has been selected for the material, then after the width of the loaded material is detected, the front edge of the material is aligned with the cutting-start area.

```
PRESS SETUP KEY
```

```
WIDTH LENGTH
28920 ---
```

- If a pinch roller is positioned over an area where there is no grit roller, the message shown at right appears when you press the **(SETUP)** key.
If this occurs, lower the sheet loading levers and move the pinch rollers to the proper positions above the grit rollers.
Reposition the material to match this new alignment, then lower the sheet loading levers to hold the material in place.

```
Change Pinch
Roller Position
```

- 11** Press the **(MENU)** key once to display the top menu.

Top menu

```
1 CUT      50cm/s
0.250mm   30gf
```

Press **(MENU)** once.

```
AREA      AXIS
RELOT     SUBMENU
```

Use ◀ or ▶ to select.
Press **(ENTER)**.

```
AREA      LENGTH
MOVE     < 5.0m >
```

Use ▲ or ▼ to change the value.
Use ◀ or ▶ to select "MOVE."
Press **(ENTER)**.

- 12**
- (1) Press the **(MENU)** key on the top menu once.
 - (2) Use the ◀ and ▶ key to move the blinking cursor to [AREA], then press the **(ENTER)** key.
 - (3) Move the blinking cursor to the numerical value under [LENGTH]. Use the ▲ and ▼ keys to set the required material length for cutting. Set this to a value that's about 0.1 m longer than the length of the cutting data.
Press **(ENTER)** key to fix the displayed values.
 - (4) Use the ◀ and ▶ keys to move the blinking cursor to [MOVE], then press the **(ENTER)** key. The material is fed out by the length set for [LENGTH].

If the material is misaligned and looks like it might come loose from the pinch rollers, or actually does come loose, please reload the material.

● To Perform Lengthy Cutting

NOTICE

When performing material feed or cutting, be sure to release the brake. Attempting to perform material feed or cutting with the brake engaged may make normal feed impossible and cause the material to slip.

Have on hand a piece of material that's at least 50 mm (2") wider than the cutting width. The chance of the material slipping loose from the pinch rollers can be reduced by braking the shaft and loading the pulled-out material while it's in a tensioned state. Follow the steps below to load the material.

- 1** Place the rolled material on the shaft and engage the brake for the shaft.

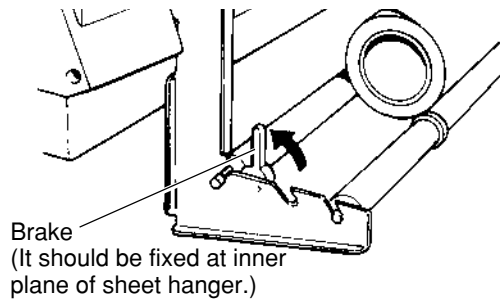

- 2** Pull out the material from the roll and pass it through the unit.

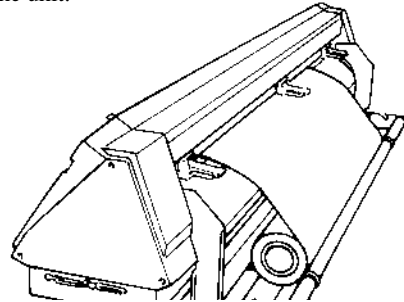

- 3** Position the left- and right-hand pinch rollers as shown in the figure. Position the middle pinch roller over the grit roller that lies between the left- and right-hand pinch rollers.

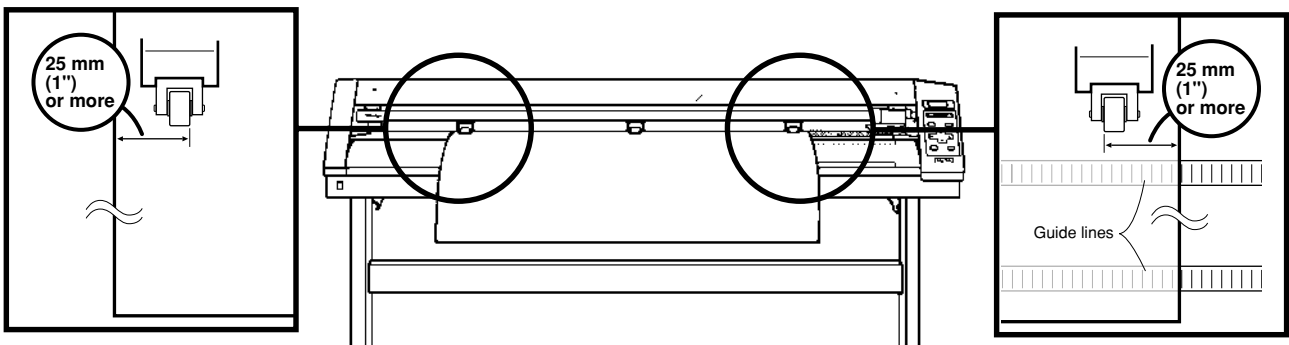

- 4** Lift the sheet loading lever. The pinch rollers are lowered and the material is secured in place. When using a material which is narrower than 762 mm (30"), do not lower the pinch rollers.

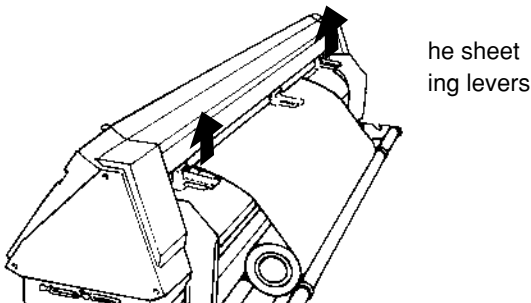

- 5** Position the stoppers so that they lightly touch the edges of the roll, and secure in place by tightening the screws.

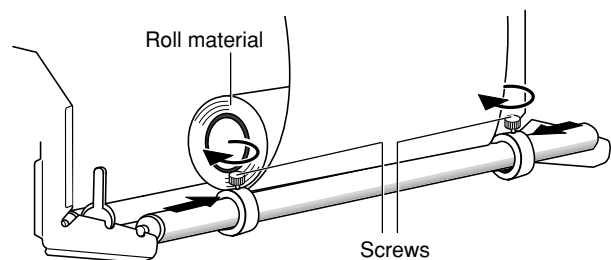

- 6** Release the shaft brake.

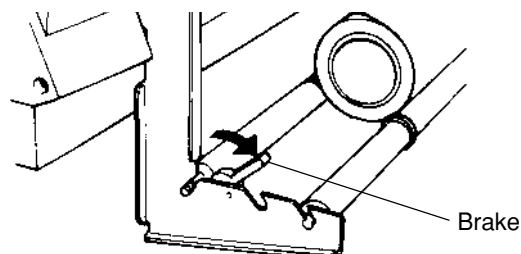

7 Use the control panel to make the following setting.

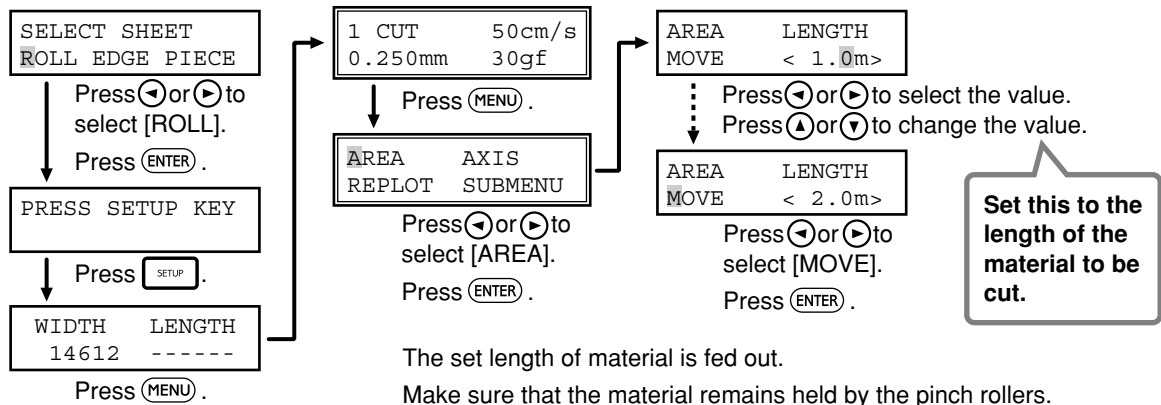

The set length of material is fed out.

Make sure that the material remains held by the pinch rollers.

If the material does come loose from the pinch rollers, set it in place again.

● Loading Flat Material (Standard-size Material, Cut Material, Etc.)



- If the material tends to reroll in the direction of its top surface (the cutting surface), roll the material in the other direction so that its backing paper is bent inward. If you perform cutting without changing the direction of the crease, the material may rise up during cutting and become caught on the front cover.
- If the material strikes the shaft during cutting, remove the shaft.

1 Lower the sheet loading levers and pass the material between the pinch rollers and the grit rollers.

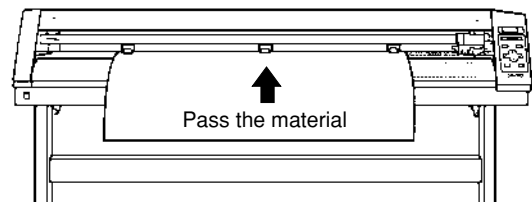

2 Follow steps 4, 5, and 6 of "● Loading Roll Material" to load a piece of material.

3 Close the front cover. Use the ◀ and ▶ keys to select [PIECE], then press the [ENTER] key.

Close the front cover

```
SELECT SHEET
ROLL EDGE
PIECE
```

4 Press the [SETUP] key. The tool carriage will move from side to side and the material will move forward and backward to detect the size of the material. When sensing ends, the display shows the loaded material size.

```
PRESS SETUP KEY
```

```
WIDTH LENGTH
28920 150
```

- If a pinch roller is positioned over an area where there is no grit roller, the message shown at right appears when you press the [SETUP] key.
If this occurs, lower the sheet loading levers and move the pinch rollers to the proper positions above the grit rollers.
Reposition the material to match this new alignment, then lower the sheet loading levers to hold the material in place.

```
Change Pinch
Roller Position
```

When detecting the material size in step 4, if the material is misaligned and looks like it might come loose from the pinch rollers, or actually does come loose, please reload the material.

4-3 About the Cutting Area

The cutting area along the horizontal plane (the direction in which the tool carriage moves) is determined by the position of the pinch rollers. The workable area spans the length between the two rollers, minus a margin of about 1 mm (about 0.04") on both sides.

If the material length is greater than 1,600 mm (62-15/16") when a flat material (paper) has been loaded, the CM-500/400/300 determines it to be a rolled material and sets the material length to 24,998 mm (984-1/8"). Also, when loading flat material (that is, when [PIECE] has been selected), a piece of material that is about 100 mm (3-15/16") longer than the vertical size of the cutting data is required.

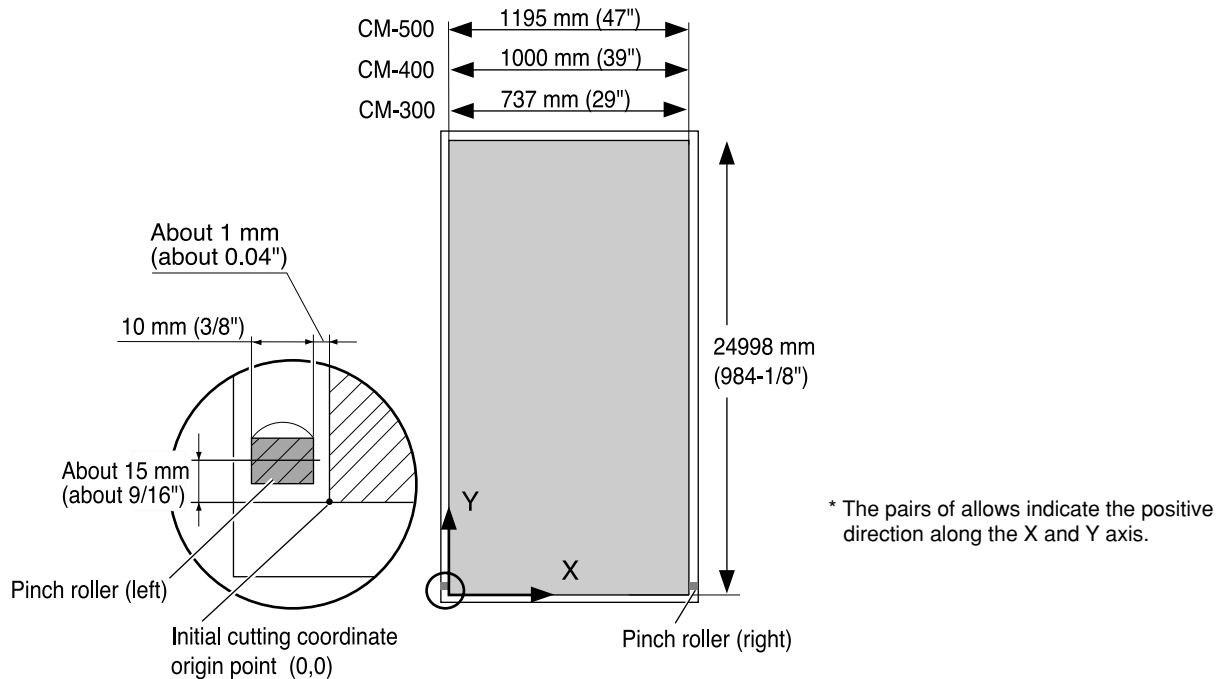

4-4 Setting the Origin Point

The CM-500/400/300 allows the origin point (0,0) to be set at any position in the cutting area.

Loading material and pressing the **SETUP** key causes the first origin point to be determined. The origin point that's determined first when the **SETUP** key is pressed differs according to what you selected for [SELECT SHEET] with the control panel when loading the material.

- | | |
|-----------|--|
| [ROLL] | Set near the left-hand pinch roller |
| [EDGE] | Set at the lower-left area of the material |
| [PIECE] | Material size is detected and the origin is set at the lower-left area of the material |

If there is no need to move the origin initially set, then it is not necessary to make the origin point setting immediately after loading a material.

You can also set the origin to an uncut area of a material in order to use the material with maximum effectiveness.

Press the **MENU** key to display the message at right.

Use the **←**, **→**, **▲** and **▼** keys to move the tool carriage to the desired location.

Press the **ENTER** key to set the origin.

```
ORIGIN SET->ENTER
      0      0
```

4-5 Cutting Test (How to Adjust Pen Force and Blade Extension)

Before carrying out actual cutting, you may wish to perform a "cutting test" to check whether the unit produces the cutout satisfactorily. This is done by examining the results of the cutting test, and adjusting the blade force and the amount of blade extension. The cutting test should be repeated until the appropriate cutting conditions for the material in use are discovered.

Cutting Test

1 Install a blade and load a material, then close the front cover.

2 Press the **MENU** key until the screen shown at below appears.

```
ORIGIN SET->ENTER
  0      0
```

3 Use the **◀**, **▶**, **▲** and **▼** keys to move the tool carriage to the place where the cutting test is to be performed.

4 Press the **TEST** key for 0.5 seconds or more. Cutting test starts. The resulting cutouts will then appear as illustrated.

- Note that an area of approximately 2 square centimeters (a little less than a square inch) is required to make a test cutout (given that the tip of the cutter after it has moved is at the origin at lower-left).

Origin
(Position of the tool installed in step 3) —●

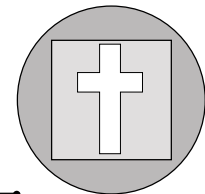

Check the state of the cutting speed and the blade force.

(1) Peel off the round section (marked by).

→ When it can be peeled by itself, without disturbing the square (marked by) , the cutter force is set appropriately.

(2) Remove the square section (marked by).

→ The optimum blade pressure is correct if you can clearly make out the lines left by the blade.

(3) The remaining cross-shaped area is used to check whether the offset value is set correctly.

When the offset value has been correctly set, the corners of the figure should appear cleanly cut as shown in A of the figure below.

If the offset value is too small, the corners will appear slightly rounded as illustrated by B; an offset value which is too large will result in a cut figure similar to C.

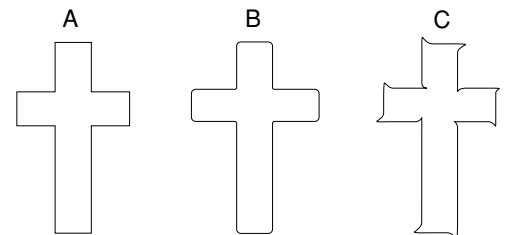

If the results of steps 1 and 2 show that the cutting quality is not acceptable, refer to "Adjusting the Blade Force" to adjust the blade force.

If adjusting the blade force doesn't improve the cutting quality, refer to "Adjusting the Blade Extension" to adjust the blade extension. After adjusting the blade extension, carry out a cutting test and adjust the blade force.

If the results of step 3 show that the blade offset isn't appropriate, refer to "4-1 Installing a Blade - How to Set the Blade Offset" and adjust the blade offset.

Adjusting the Pen Force

Set the Pen Force slider at the center (default) position.

Press the **(MENU)** key to display the message at below.

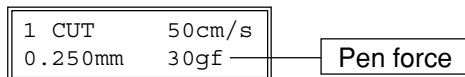

Setting range: 20—350 gf (in increments of 10 gf)

- Use the **(◀)** and **(▶)** keys to move the blinking cursor to the item to be set.
- Then use the **(▲)** and **(▼)** keys to change the numerical value, and press the **(ENTER)** key to enable the setting.

After using the control panel to set the pen force, if you want to raise or lower the blade force slightly according to the blade length, you can use the Pen Force slider to make fine adjustments in the pen force.

Move the slider to the right or left to gradually raise or lower the pen force and set it at an appropriate value.

The range of fine adjustment for pen force using the Pen Force slider is within 30 gf up or down from the value set with the control panel.

When using the control panel to set the pen force, move the Pen Force slider to its center (default) position.

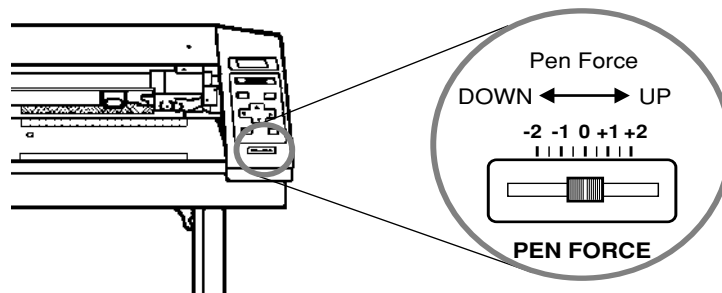

Adjusting the Blade Extension

The amount of cutter blade extension can be adjusted by rotating the cap. If it is necessary to adjust the amount of blade extension, remove the blade holder, adjust the amount of blade extension as shown in the figure below, then remount the blade holder on the cutting carriage.



When using the included material or a general type of equivalent material, the unit should generally be used with the cap tightened at its highest position (maximum blade extension = 2.5 mm (0.0984")). When cutting material having base paper that is thin with respect to the material (material thickness), or material having no base paper, the amount of blade extension should be adjusted so that the blade does not cut through the base paper.

Each indicator tick corresponds to 0.1 mm, and adjustment for 0.5 mm can be made by rotating the cap one full turn

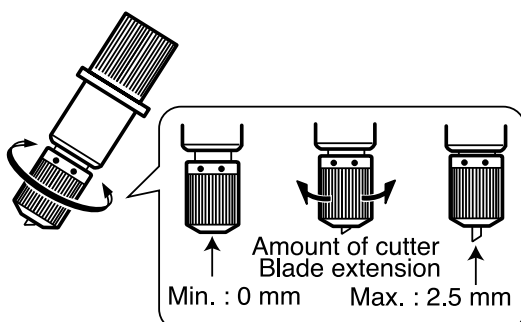

[Adjusting the amount of blade extension]

Perform a cutting test and gradually extend the blade. Take care to ensure that the amount of blade extension does not exceed the thickness of the material portion plus the thickness of the base paper.

$$\text{Amount of cutter blade extension} = \text{Thickness of the material portion} + \frac{\text{Thickness of the base paper}}{2}$$

If the blade leaves a faint mark on the base paper, the amount of blade extension is optimal.

Incorrect cutting conditions may cause symptoms such as those described below.

Blade force

- The sheet is easily torn.
- The cutter requires frequency replacement.
- Cutting extends through the base paper, and normal advancing of the sheet becomes impossible.
- The unit suffers damage.

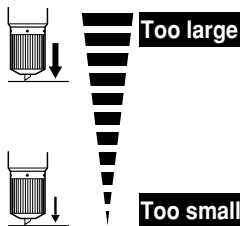

Some parts of the sheet remain uncut.

Blade offset

Corners flare outward, with "horns." 

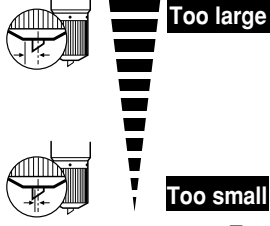

Corners are rounded. 

For Materials with a Strong Adhesive Layer

If you are using a material with a strong adhesive layer, the adhesive layer may adhere to itself immediately when cut. This means that even though the material has actually been cut, it may appear as if it has not been cut, and blade force may mistakenly be set too high. If a cutting test shows that the material peels easily and the blade traces on the carrier paper are optimal, then the material is being cut. Take care not to set the blade force excessively high.

4-6 Downloading Cutting Data

The unit will begin cutting when it receives cutting data sent from computer.

Software Setting

Make the settings described below to match the program that you're using.

If you're outputting the data from a Windows-based program, select either [CM-500], [CM-400], or [CM-300] as the printer.

If you're outputting the data from an MS-DOS-based program, selection the CM-500/400/300 as the output device. If the CM-500/400/300 is not an available selection, choose the PNC-1860, PNC-1410, PNC-1210, PNC-1850, or PNC-1200 (models supporting CAMM-GL III).

For the interface connection, choose the type of interface you're using to connect the host computer with this product.

Select either the parallel (Centronics) or serial (RS-232C) interface. Choose the one that the host computer and the CM-500/400/300 are connected by.

Pausing Cutting Operations

If you want to stop the CM-500/400/300 momentarily while it is performing cutting, follow the procedure described below.

Press the  key.

Cutting is paused and the screen shown at right appears on the display.

PAUSE ON
CONT. STOP VIEW



[Continue cutting]

Press the  key.

Cutting is resumed.



[To Terminate Cutting]

First of all, stop the flow of data being sent by the computer.

Use the  and  keys to choose "STOP" and press the  key. Cutting stops and the display returns to the top menu.







[Checking the Status of Cutting]

The tool carriage can be moved toward the control panel to allow the cutting status to be checked visually.

Use the  and  keys to choose "VIEW" and press the  key. The tool carriage moves toward the control panel. To resume cutting, follow the procedure described in "Continue cutting" above.

Repeating the same cutting







The "Replot" feature allows you to create numerous copies of same cutting.

- (1) Press the  key until the screen shown at right appears, then use the  and  keys to select "REPLOTT" and press the  key.
- (2) Use the  and  keys to select "START," then press the  key to begin replotting.

AREA	ROTATE
REPLOTT	SUBMENU

REPLOTT	
START	CLEAR

The Replot function calls up all data in the data buffer and performs cutting with this data. When performing replotting, follow the steps below to delete the data in the data buffer before send the data to be replotted from the computer.

- (1) Press the  key until the screen shown at right appears, then use the  and  keys to select "REPLOTT" and press the  key.
- (2) Use the  and  keys to select "CLEAR" and press the  key to delete the data in the data buffer.

AREA	ROTATE
REPLOTT	SUBMENU

REPLOTT	
START	CLEAR

4-7 Applying the Completed Cutout

Once cutting has been completed, follow the procedure below for application instructions.



- Make sure beforehand that the surface where the work is to be stuck is clean and free of all dust or oily deposits.
- When applying the work to a transparent surface, such as a window, you can use a water-based pen (which can be wiped off afterwards) to mark guidelines on the reverse side of the glass, to aid in getting the work aligned properly.
- If you discover after it is stuck in place that air bubbles were trapped under the work, use a needle to puncture them. Then you can smooth out the material out so that it sticks securely.

- 1** With the CM-500/400/300, the portion where you've performed cutting is automatically cut off from the material. Press the  key to cut off the portion from the material.

If you want to remove the material, then open the front cover, press down the sheet loading levers, and then remove the material.

- 2** Strip/Weed uses all unneeded portions from the completed work.

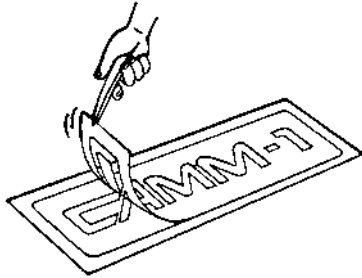

* You should have weed borders or rectangles drawn around work to facilitate weeding.

- 3** Stick application tape over the completed work. Press down firmly on the application tape to remove air bubbles. If you do not press firmly enough the cut area will not stick to the surface.

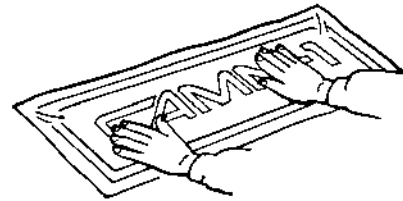

- 4** Transfer the material to the application tape, position it, and carefully affix it, making sure that it is aligned correctly. Rub over the application tape to make sure the work is firmly stuck in place. Then peel off the application tape.

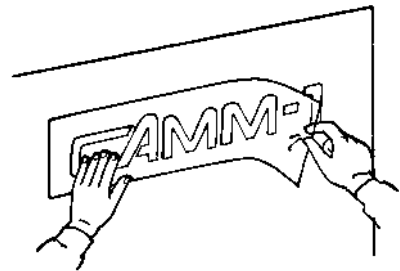

4-8 When Cutting is Completed

CAUTION



When not in use for extended periods, unplug the power cord from the electrical outlet.

Failure to do so may result in danger of shock, electrocution, or fire due to deterioration of the electrical insulation.

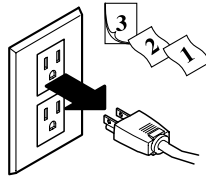

NOTICE Do not leave the tool mounting screws tightened. Tightening the screw makes it more difficult to install the blade holder.

- 1** Lower the sheet loading levers and remove the material.

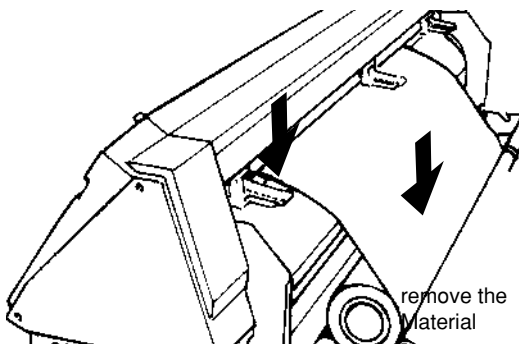

- 2** (1) Loosen the tool securing screw on the cutting carriage.
(2) Remove the blade holder from the cutting carriage.

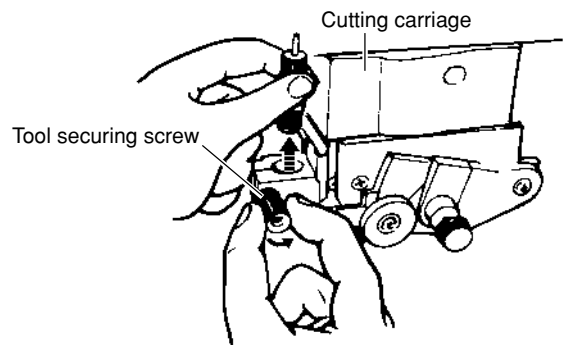

- 3** Press the push-pin and remove the blade from the blade holder.
If a blade was used, wipe the blade with a soft cloth to remove any material that may cling to it.

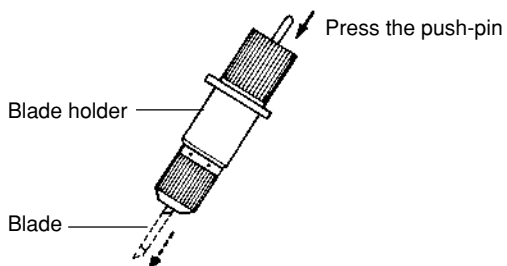

- 4** Turn off the power.

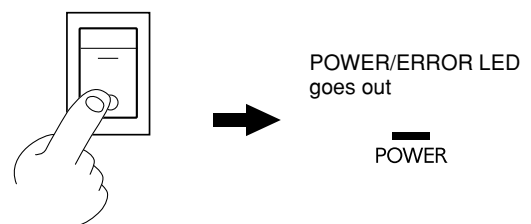

5 Maintenance

5-1 Cleaning

NOTICE Always turn off the CM-500/400/300 before cleaning it.

Never lubricate the mechanisms.

Do not clean with solvents (such as benzine or thinners).

Cleaning the body

Use a cloth moistened with water then wrung well, and wipe gently to clean. Wipe the operation panel and display gently with a clean, soft cloth.

Cleaning the platen

Use a cloth moistened with water then wrung well, and wipe gently to clean.

Cleaning the grit rollers

With the sheet loading levers lowered and the pinch rollers raised, use a commercially available brush to remove dust and other detritus. Brush horizontally while rotating the grit rollers.

If dust builds up it may prevent the paper from being held securely, and degrade plot precision.

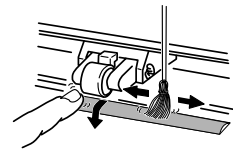

Cleaning the pinch rollers

Lower the sheet loading levers and raise the pinch rollers.

Use a cloth moistened with water then wrung well, and wipe gently to clean.

Cleaning the front cover

Use a cloth moistened with water then wrung well, and wipe gently to clean. If severe a neutral detergent may be used. Never use anything other than water, or a neutral detergent.

Cleaning the blade holder cap

If material debris is adhering to the inner surface of the cap for the blade holder, loosen and remove the cap, then remove the material debris.

5-2 How to Replace the Separating Knife

CAUTION



Make sure the power to the unit is off before attempting to replace the separating knife.

Doing so may result in injury.

If the separating knife, replace it with the replacement blade included with the CM-500/400/300. Follow the steps below to replace the blade.

- 1** Switch off the power to the CM-500/400/300.

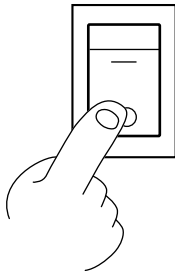

- 2** Remove the separating knife.
(1) Loosen the screw until it slips out.
(2) Grasp the screw portion, and slowly pull it out in the direction of the arrow.
* Do not pull back while doing this.

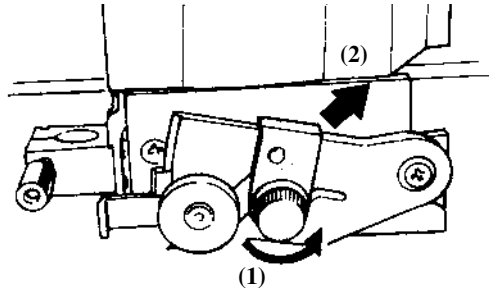

* If the blade remains in the carriage, use the included tweezers to remove it.

- 3** Replace with a new knife.

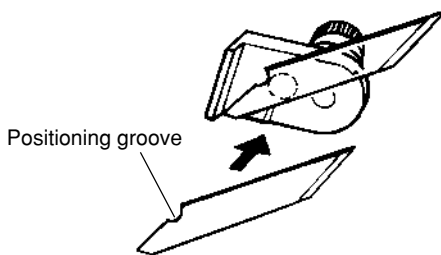

The knife is secured in place by the magnet.

- 4** Install the separating knife.
(1) Grasp the screw portion and slowly insert it into the groove.
* Take care to ensure that the knife does not slip
(2) Tighten the screw.

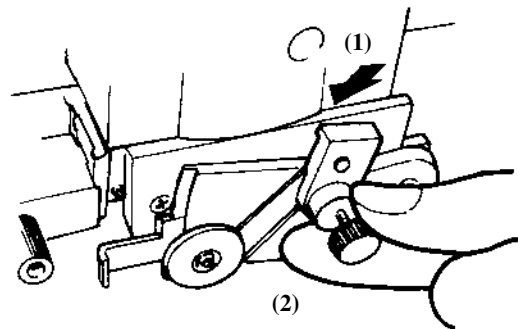

6 Using the Display Menus

This section describes the basic steps for using the display menus. Use this information together with "7 Display Menus Flowchart" on the following page to make menu settings.

Use the \leftarrow and \rightarrow keys to move the blinking cursor ("█") and choose a setting. Then use the \uparrow and \downarrow keys to change the value (or the selection) and enable the setting by pressing the ENTER key.

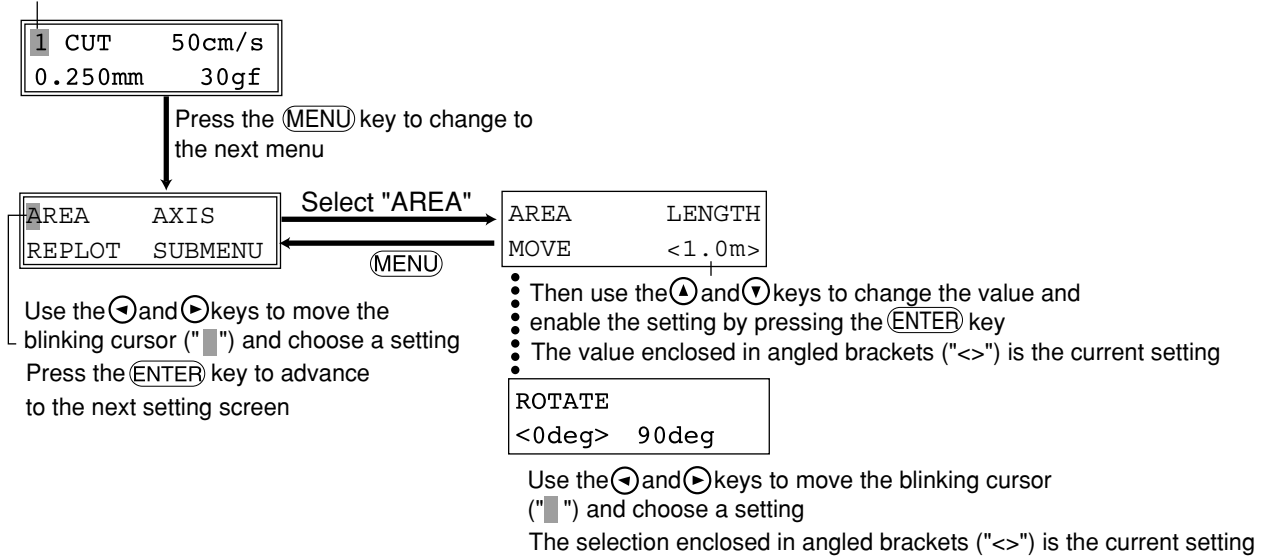

- To return to the menu selection screen from any of the menu value setting screens, press the MENU key.
- To return to the previous screen without changing the numerical settings, pressing the MENU key without pressing the ENTER key.

7 Display Menu Flowchart

For details about each of the menus, see the "8 Display Menu Lists."

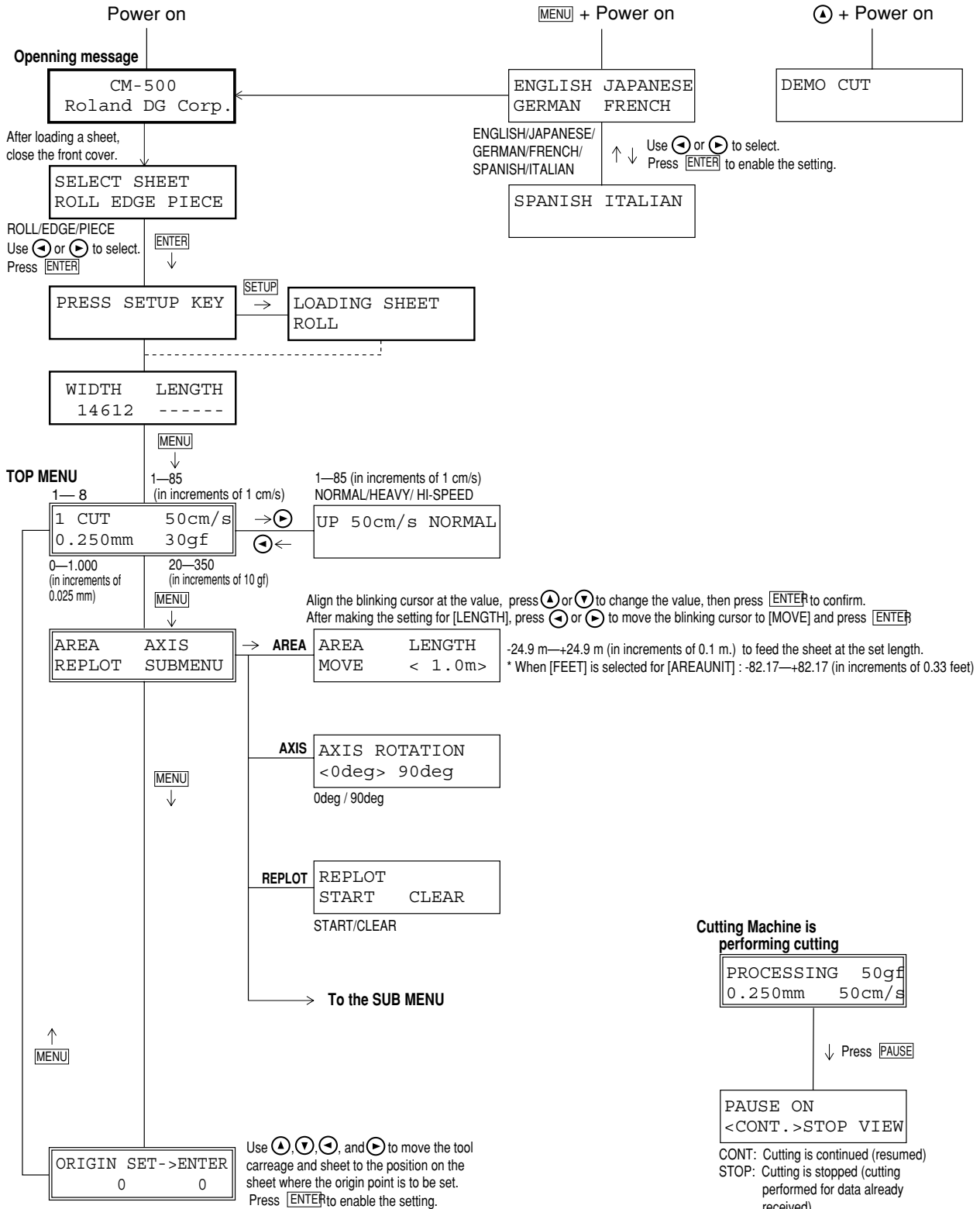

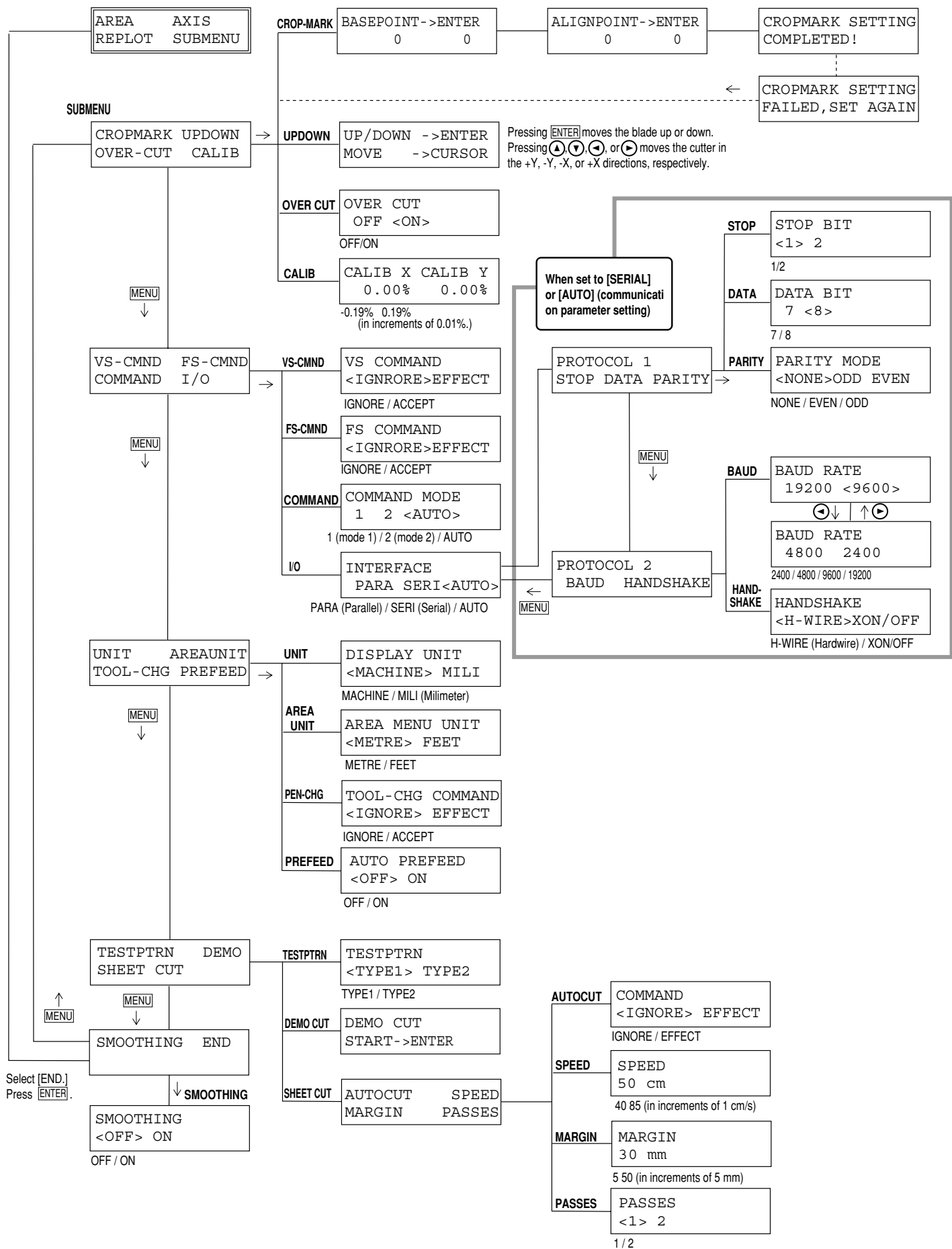



8 Display Menu Lists

This chart lists the menus of the CM-500/400/300 grouped by usage. Menus indicated by an Circle ("○") are explained further in the section at the end of the chart. Please refer to these additional explanations when using such menus.

MENU	Explanation	Default
Determining the type of sheet loaded		
SELECT SHEET	This selects the type of material to be used ("ROLL," "EDGE," or "PIECE").	-
Setting cutting conditions		
1—8	It is possible to set the cutting parameters (plotting parameters) to match the tool and material (pen and paper condition), and store them for later use. Five items can be stored: cutting speed, blade compensation, blade force, tool movement speed during tool-up, and CUT QUALITY. These settings can be stored in memory as eight patterns (numbered 1 through 8).	-
** cm/s	This sets the speed blade for during cutting. Perform a cutting test and set the conditions to match the loaded material and the installed cutter.	50 cm/sec.
*. **mm	This sets the amount of offset for the blade during cutting. Perform a cutting test and set the conditions to match the loaded material and the installed cutter. When using the included test material and blade or equivalent parts, cutting can be performed using the factory-default settings.	0.250 mm
**gf	This sets the force for the blade during cutting. Perform a cutting test and set the conditions to match the loaded material and the installed cutter.	50 gf
SMOOTHING	If you want the curves of circles and arcs to be cut smoothly, set this to "ON." When on, however, small text or intricate designs may also be cut with rounded corners. If this happens, change the setting to "OFF" and perform cutting again.	ON
NORMAL (CUT QUALITY)	This sets the cutting quality. Ordinarily this is left set to "NORMAL." When rapid cutting is desired, such as when cutting a large material, set this to "HI-SPEED." When load is large, or if the material is not cut smoothly, or when small text is to be cut attractively, set this to "HEAVY."	NORMAL
UP	This sets the speed of movement when the tool is raised and moves to the next position for cutting during a cutting operation.	50 cm/s
○ 1 OVER CUT	This cuts an excess margin of 1 mm (1/16") from the first and last line segments. This selection is normally left set to "OFF," and is set to "ON" when cutting especially attractive corners is desired. When cutting small text or intricate graphics, however, this should be set to "OFF" to avoid cutting into the material.	OFF
Setting the origin point		
ORIGIN SET	Set a user origin at an arbitrary point on the material. After the material has been loaded, be sure to set the origin to the bottom left of the material.	-
Rotating the origin point		
○ 2 AXIS ROTATION	This rotates the cutting coordinate origin by 90 degrees. This is normally set to "0deg," which means that the origin is at the bottom left of the material. Setting this to "90deg" moves the origin to the bottom right of the material, thereby rotating the cutting pattern by 90 degrees. * Don't forget that the coordinate axis changes when the origin is rotated.	0deg

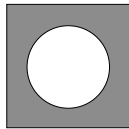
MENU	Explanation	Default
Feed the loaded material		
AREA	This moves the material by the length to be cut before actual cutting is performed, making it possible to ensure that the material will not slip or come loose during cutting. When performing continuous cutting on the same material, this can also be used to make sure that there is enough remaining material to cut the data that will be sent.	1.0 m
AREA UNIT	Sets the units used to specify length in display menu "AREA". Units may be set to either "METRE" or "FEET".	METRE
PREFEED	Set to on for automatic material feed at cutting. If this is set to on, when cutting data is sent from the computer, the plotter will automatically execute cutting after a 1 m (39-3/8") feed. After the material is loaded be sure to feed the material by the length needed for cutting with the "AREA" function. (Some data may cause feed over 1 m (39-3/8"), such as when the next point of movement is located more than 1 m (39-3/8") to the rear.) * If the "AREA" function is used to feed the material in advance, the material will not be automatically fed even when "PREFEED" is set to on.	OFF
Align the axis		
○3 CROPMARK	This is used when cutting materials with alignment marks (crop marks) printed around the graphics, such as for making stickers or seals. The crop marks are set as reference points and correction points, enabling the graphics to be cut with accuracy.	-
Correct for the cutting distance error based on actual measurement		
CALIB	This adjusts the respective distances of the X and Y axes. Compare the actual measurements of the cutting results with the data sent from the computer to calculate and set the distance adjustment value.c	0.00%
Repeating the same cutting - Deletes any data in the replot buffer		
REPLOT	This cuts the data in the replot buffer. Selecting "Clear" causes existing data in the replot buffer to be deleted.	-
Selecting the instruction set		
COMMAND MODE	This selection enables the type of instructions that are understood by the unit. You can set the unit to accept either CAMM-GL III mode 1 instructions ("1") or mode 2 instructions ("2"). When set to "AUTO," the CM-500/400/300 automatically detects the type of instructions first received after turning on the power, and sets itself to accept those instructions. To change the type of instructions, first change the setting, then switch the power to the unit off and back on again.	AUTO
Selecting the connection interface		
INTERFACE	This selects the interface for connecting a computer to the CM-500/400/300. Set this to "PARALLEL" for a parallel connection or to "SERIAL" for a serial connection. When set to "AUTO," the CM-500/400/300 automatically detects whether a parallel or serial type interface is used when data is first received after turning on the power, and sets itself accordingly.	AUTO
Setting the protocol for a serial connection		
STOP BIT	This marker tells the system when a character data set end.	1
DATA BIT	The size (length) of one block of data.	8
PARITYMODE	Parity is used to check whether data was received correctly.	NONE
BOUD RATE	Determines the speed of data transmission.	9600
HANDSHAKE	Sets the handshake mode for when the CM-500/400/300 is connected the host computer via the serial interface.	H-WIRE

MENU	Explanation	Default
Giving priority to settings from the computer		
TOOL-CNG COMMAND	This is normally set to "IGNORE" when performing cutting. When a tool-selection instruction (SP instruction) is sent from the computer while this is set to "EGNORE," the SP instruction is ignored and operation continues without pause. When set to "EFFECT," SP exchange instructions are accepted and operation pauses. If tool change is needed, open the front cover, change the tool, then press the ENTER key.	IGNORE
VS COMMAND	To perform cutting at the speed determined by a VS command (tool speed setting command) sent from the computer, set this to "EFFECT". When set to "IGNORE", cutting is performed using the values for "** cm/s" and "UPSPEED" set at the top menu.	IGNORE
FS COMMAND	To perform cutting at the tool force determined by an FS command (tool force setting command) sent from the computer, set this to "EFFECT." When set to "IGNORE," cutting is performed using the values for "** gf" set at the top menu.	IGNORE
This chooses a cutting-test pattern.		
TESTPTRN	This performs an ordinary cutting test with [Type 1]. For thin materials or cases where graphics are too small to obtain good cutting results with [Type 1], make the setting for [Type 2]. <div style="display: flex; justify-content: space-around; align-items: center;"> <div style="text-align: center;"> <p>TYPE1</p>  </div> <div style="text-align: center;"> <p>TYPE2</p>  </div> </div>	TYPE1
This sets the material cutoff conditions.		
AUTO CUT (Material cutoff)	To enable AUTO CUT (material cutoff) using a command, set this to [Enable]. Regardless of whether the setting is at [Enable] or [Disable], the material can be cut off by pressing the  key.	IGNORE
SPEED	This sets the AUTO CUT (material cutoff) speed. Set this to a suitable speed for the loaded material and installed blade.	50 cm/s
MARGIN	This sets the amount of margin from the cut edge of the material for the next starting point for cutting after cutting off the material.	30 mm
PASSES	This sets the number of times material cutoff is performed (once for [1] or twice for [2]). When working with thicker material or other material that's difficult to cut, set this to [2]. Pressing the  key once performs material cutoff the number of times set here.	1
Other setting		
ENGLISH, JAPANESE, GERMAN, FRENCH, SPANISH, ITALIAN	The CM-500/400/300 is capable of displaying all its menus in either of six languages, English, French, German, Spanish, Italian and Japanese.	ENGLISH
UNIT	This sets the type of unit for coordinate values that appear on the display. Set this to "MECHANICAL UNIT" for display in cutting coordinate units (1 = 0.025 mm), or to "MILLIMETER" for display in millimeters.	MILLIMETER
DEMO CUT	This performs an operation check when the CM-500/400/300 is not working correctly.	-
UP/DOWN MOVE	This moves the tool up or down. It also moves the tip of the blade in any of four directions (-X, +X, -Y, or +Y). With the tool down, the tool carriage can be moved with the four cursor keys to cut the sheet.	-

○ 1 OVER CUT

Cutting results differ as shown in the following figures depending on whether the Overcut function is on or off.

OVER CUT: OFF

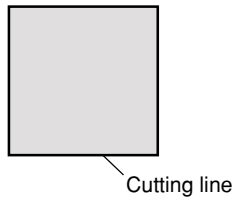

OVER CUT: ON

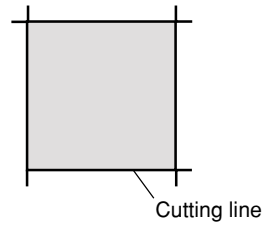

○ 2 ROTATE

Whenever you employ the Rotate function (which allows you to rotate a character 90 degrees), the origin will be located at the material's lower-right.

[0° Rotation]

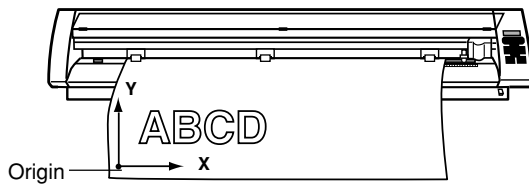

[90° Rotation]

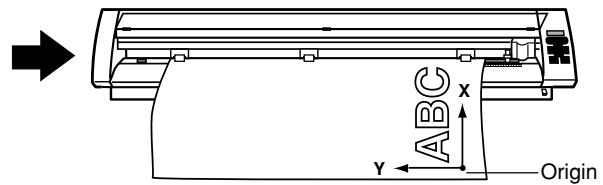

○ 3 CROPMARK

This is used when cutting around pre-printed graphics on a material, such as when making stickers or seals. With the CM-500/400/300, a material is always loaded parallel to the unit. This means that unless the graphics to be cut have been printed parallel to the material, the cutting lines become shifted from the graphics, and it becomes impossible to accurately cut around the graphics (see Figure A below). If the printed graphics have crop marks, the positions of the crop marks can be stored in memory and used as reference points by the CM-500/400/300. By making this setting, it becomes possible to cut around graphics with accuracy even when the graphics have not been printed parallel to the material (Figure B).

Crop mark:  Cutting line: - - - - -

A When the crop mark setting has not been made

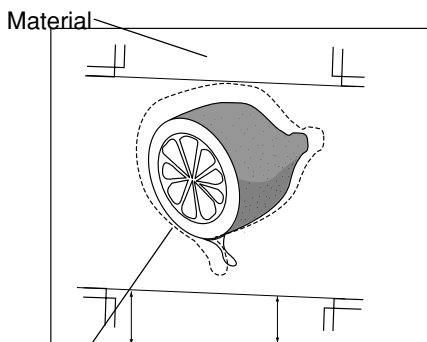

Accurate cutting around the graphic becomes possible

B When the crop mark settings has been made

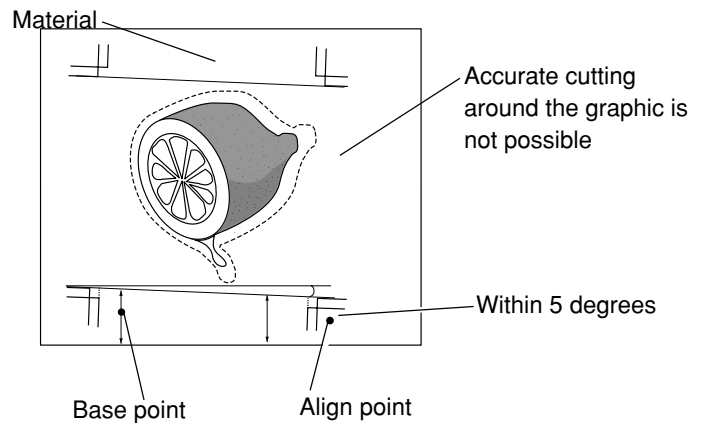

The methods for setting crop marks are described on the next page. Please refer to the figures shown above while making this setting.

CAUTION



Do not place hands near the platen while in operation.

Doing so may result in injury.

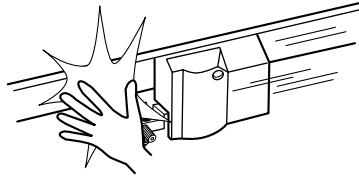

- The crop mark setting cannot be made if the angle of the base point and the align point is more than 5 degrees.
- Crop marks cannot be set when the "ROTATE" display menu is set to "90 deg."

Load the material (with pre-printed graphics) and install the water based fiber tipped pen included with the CM-500/400/300. The alignment tool is installed in the same way as the blade holder.

(1) Press the **(MENU)** key until the screen shown at right appears, then use the **(◀)** and **(▶)** keys to select "SUBMENU" and press the **(ENTER)** key.

(1)

AREA	AXIS
REPLOT	SUBMENU

(2) When the screen shown at right appears, press the **(ENTER)** key to change to menu for setting the base point.

(2)

CROPMARK	UPDOWN
OVER-CUT	CALIB

(3) Use the **(◀)**, **(▶)**, **(▲)**, and **(▼)** keys to move to the tool carriage to a position below and to the left of the crop mark printed on the material. Line up the water based fiber tipped pen with the center of the crop mark. After the alignment tool has been positioned correctly, press the **(ENTER)** key. The display then advances to the menu for setting the align point.

(3)

BASEPOINT -> ENTER
0 0

(4) Use the **(◀)**, **(▶)**, **(▲)**, and **(▼)** keys to move to the tool carriage to the crop mark printed at the lower right of the material. Line up the water based fiber tipped pen with the center of the crop mark. After the alignment tool has been positioned correctly, press the **(ENTER)** key.

(4)

ALIGNPOINT -> ENTER
0 0

(5) When the crop mark setting has been made successfully, the display shows screen (A), then returns to the screen shown in step (2). Replace the alignment tool with a blade. If the crop mark setting could not be made, the display shows screen (B) before returning to the screen shown in step (2). If this happens, reload the material and make the setting again.

(A)

CROPMARK SETTING COMPLETED !

(B)

CROPMARK SETTING FAILED, SET AGAIN

9 About the Blades and Materials

This section indicates the proper cutting conditions for various types of materials, as well as blade lifespans. Cutting conditions and blade life vary according to the hardness of the material and the usage environment. Making the settings for the conditions described below does not automatically guarantee attractive cutting results in all situations. Before performing actual cutting, be sure to carry out a cutting test and make any necessary adjustments (see "4-5 Cutting Test"). If the material is not cut through completely even when the tool force is increased by 50 to 60 gf more than the tool force values shown below, it means that the useful life of the blade has ended. Replace with a new blade.

Blade	Material	Tool-force	Speed	Amount of cutter blade extension	Life of a blade (General guide)
ZEC-U1005	General Signage Vinyl	50 — 150 gf	85 cm/sec.	0.25 mm (0.01")	8000 m
ZEC-U5025	General Signage Vinyl	30 — 100 gf	85 cm/sec.	0.25 mm (0.01")	4000 m
	Reflective Vinyl	120 — 200 gf	85 cm/sec.	0.25 mm (0.01")	4000 m
	Fluorescent Vinyl	100 — 200 gf	85 cm/sec.	0.25 mm (0.01")	4000 m
ZEC-U1715	Rubber material for sandblasting stencil	100 — 200 gf	20 cm/sec.	0.25 mm (0.01")	Varies according to material type

* The values for lifespan are intended to serve as a general guide when cutting materials of identical type.

Rubber materials for sandblasting stencils which can be cut:

- A) Materials with a material thickness of 1 mm (0.04") or less
- B) Materials with only carrier paper on both flanks of the material (Position the left and right pinch rollers above the strips of carrier paper.)
- C) Materials with carrier paper which is hard enough to withstand material feed



About the Separating Knife:

It may not be possible to sever some thicker materials (such as rubber sandblasting templates) or thin, flimsy materials. In such cases, use a commercially available cutter knife or scissors to cut off the material.

Material with a strong tendency to reroll (that is, with a warp in the direction of the cutting surface) may catch on the carriage or the front cover after being cut off.

10 Plotting on Paper Media

NOTICE Do not use coated paper. The coating may flake or peel off and adhere to the grit rollers, making it impossible to perform cutting (or plotting) correctly.

Before cutting, plotting using pen and paper can ensure that your design is correct without wasting materials.

This feature can also be used to plot template designs on thick materials that may not be able to be cut.

* Since the design of the CM-500/400/300 differs inherently from that of dedicated plotters, it does not accommodate functions such as high-speed plotting, automatic pen changes, pen dry protection, or the like.

Acceptable pens and paper media

	Acceptable paper	Acceptable paper widths	Acceptable pens
CM-500	High-quality paper	Min.90 mm (3-1/2") Max.1372 mm (54")	Water-based fiber-tipped pens Thick water-based fiber-tipped pens
CM-400	High-quality paper	Min.90 mm (3-1/2") Max.1178 mm (46")	Water-based fiber-tipped pens Thick water-based fiber-tipped pens
CM-300	High-quality paper	Min.50 mm (2") Max. 915 mm (36") (50—540 mm (2"—21") , 582—915 mm (23"—36"))	Water-based fiber-tipped pens Thick water-based fiber-tipped pens

Menu Settings for Plotting

To perform plotting on a material of paper or the like, first use the display menus to make the settings described below.

If attractive plotting is impossible, adjust the setting parameters within the ranges shown below.

1. Tool No. (see "8 Display Menu Lists/Setting cutting conditions/1—8")

When "Blade offset" is set to "0.000 mm," the tool number shown on the upper line of the display changes from "CUT" to "PEN."

Select the tool number to be set and make the settings for conditions 2 through 5. Please note that if a tool number for which cutting conditions have previously been set is selected, the earlier conditions are deleted.

2. Pen Speed (see "8 Display Menu Lists/Setting cutting conditions/ ** cm/s")

Water based fiber tipped pen / Thick water based fiber tipped pen: 10—50 cm/sec

Set a low Pen Speed value to ensure clear plots with no faintness.

3. Pen Force (see "4-5 Cutting Test (How to Adjust Blade Force/Adjusting the Cutter Blade)")

Water based fiber tipped pen : 30—60 gf

Thick water based fiber tipped pen : 40—120 gf

4. Blade offset (see "4-1 Installing a Blade/How to Set the Blade Offset")

Set this to "0.00 mm."

5. Cut quality (see "8 Display Menu Lists/Setting cutting conditions/NORMAL (CUT QUALITY)")

Set this to "Normal."

6. Setting for pen change instructions

If CAD software for plotting use has been used to output data (in RD-GL I format), pen-change instructions are sent to the CM-500/400/300. If the pen is to be changed during plotting, use "1. Tool number" to set the tool numbers to be used to match the pen numbers set with the software. Because tool changes are not necessary when cutting is performed, the CM-500/400/300 is ordinarily set not to accept pen-change instructions. This setting makes it possible to enable the CM-500/400/300 to accept and execute pen-change instructions.

(1) Press the **(MENU)** key until the screen shown at right appears, then use the **(◀)** and **(▶)** keys to select "SUBMENU" and press the **(ENTER)** key.

```
AREA      AXIS
REPLOT    SUBMENU
```

(2) Press the **(ENTER)** key, then press the **(MENU)** key twice the screen shown at right appears. Then use the **(◀)** and **(▶)** keys to select "TOOL-CHG".

```
UNIT      AREAUNIT
TOOL-CHG  PREFEED
```

(3) Press the **(ENTER)** key to display the screen shown at right, then use the **(◀)** and **(▶)** keys to select "EFFECT" and press the **(ENTER)** key.

```
TOOL-CHG  COMMAND
IGNORE    <EFFECT>
```

Depending on the setting made for "6. Setting for pen change instructions," operation is paused when a tool-change instruction is received while plotting is in progress. To change the tool, open the front cover and exchange the tool. Then press the **(ENTER)** key to resume cutting.

```
TOOL-CHG : TOOLNO2
```

11 What to do if...

11-1 What to do if...

CM-500/400/300 troubleshooting

Is the power cord connected correctly?	Connect the power cord included with the CM-500/400/300 to the unit, and plug the other end securely into an electrical outlet (see "3-1 Setting Up and Connection").
Is the CM-500/400/300 power on ?	Turn on the power.
Is the front cover closed?	Close the front cover when performing cutting (see "4-2 Loading the Material").
Is the CM-500/400/300 in the temporary halt state ? Is operation paused?	<p>If the screen shown at rights is displayed, it means that operation is paused.</p> <p>To resume cutting, press the (PAUSE) key again.</p> <p>To abort cutting, first stop the flow of cutting instructions from the computer. And use the (◀) and (▶) keys to select "STOP," then press the (ENTER) key.</p>
If connected via the serial port, do the communication parameters for the CM-500/400/300 match those of the computer ?	At the display menus, make the correct settings for the communication parameters (see "3-3 Selecting the Interface").
Is the computer set up correctly ?	<p>Check the following items:</p> <ul style="list-style-type: none"> • DIP switches • Memory switches • Interface board • Communication parameters • Other settings <p>Read the computer user's manual and set it up correctly.</p>
Are the computer and the CM-500/400/300 linked with the right cable ?	The type of cable you need is determined by your computer and the software you are using. Even if the computer is the same, running different software may require a different cable. Use the cable specified in your software.

```
PAUSE ON
CONT. STOP VIEW
```

Are the computer and the CM-500/400/300 connected correctly?	Correctly connect the computer and the CM-500/400/300 (see “3-1 Setting Up and Connections”).
Is the interface setting correct?	At the display menu, make the correct setting for the interface connecting the computer and the CM-500/400/300 (see “3-3 Selecting the Interface”).
Is the OS set up correctly ?	Check the following items: <ul style="list-style-type: none"> • Output port selection • Output device selection • Output port open • Communication Parameters • Other settings Check the OS’s user’s manual and set it up correctly.
Are the application software settings correctly ?	Check the following items: <ul style="list-style-type: none"> • Output device specifications (select a device name that matches the instruction system. If the wrong device is selected an incorrect instruction may be output, resulting in an error). <ul style="list-style-type: none"> • Communication Parameters • Other settings Check the software user’s manual and set it up correctly.

A message appears on the display

Change Pinch Roller Position	The location of one or more of the pinch rollers is not correct. If this happens, lower the material loading levers and move the pinch rollers to the proper positions above the grit rollers. Reposition the material to match this new alignment, then lower the material loading levers to hold the material in place.
CLOSE COVER	This is displayed when the front cover is opened during cutting. Cutting operation is halted, and the message is displayed on the screen. Cutting restarts when the cover is closed.
Sheet Set Error Set Sheet Again	This is displayed when the material has been loaded at a position where the sheet sensor does not function. Follow the steps under "4-2 Loading the Material" to load the material so that it is positioned above the sheet sensor. This is displayed when the material is removed after pressing the SETUP key. Load a material and press any key to cancel the error message.
Motor Error Power ON Again	Shows motor error status. This is displayed when the CM-500/400/300 is heavily loaded, such as during a media jam, when heavy stock is cut across a long distance without initial material feed, or when the material is abruptly pulled from the roll during cutting. In this case, turn the power off and back on again (if a media jam has occurred, clear the jam before turning the power back on). For large cutting data with a roll material, use the “AREA” function on the display menu to feed the roll material by the length of the cut (ensure a small margin by setting a length that is about 0.1 m longer than the cutting data). When using a thick material, change the display menu setting from "NORMAL" to "HEAVY."(see “8 Display Menu Lists” /"NORMAL" (CUT QUALITY)). If the above message is displayed even after"NORMAL" (CUT QUALITY) is set to “HEAVY,” turn the power off and then back on again, and reduce the “**cm/s” value in the display menu. See “8 Display Menu Lists” / ** cm/s .

The material is not cut properly

Are the blade and blade holder installed correctly and securely ?	Install these so that there is no looseness (see "4-1 Installing a Blade").
Is the blade chipped ?	If it is, replace it with a new one (see "4-1 Installing a Blade").
Check if there are any dirty deposits on the blade.	If dirty, remove and clear the blade.
Are blade speed, blade compensation, and cutting speed appropriate for the sheet being cut?	Perform a cutting test and use the display menu to select the appropriate values (see "4-5 Cutting Test (How to Adjust Blade Force and Blade Extension)" / "8 Display Menu Lists").
Is a thick material being used?	When using a thick material, change the display menu setting from "NORMAL" to "HEAVY."
Is a wide material being used?	When using a material with a width greater than 762 mm (30"), lower the middle pinch roller at a position near the center of the material.

The Material slips away from the pinch rollers during the cutting process

Is a material with sprocket holes being used?	If a material with holes for sprocket feed is being used, placing the pinch roller above the hole portion may cause the material to slip. Be sure to set the pinch roller over the material to the inner side of the hole portion.
If a flat material (such as a standard-size material or piece material) has been loaded, has the "PIECE" setting been selected for the material type?	When loading the material, select "PIECE" for the "SELECT SHEET" display menu (refer to "4-2 Loading the Material").
Is the material being cut blocked at some position?	Make sure that the left and right edges of the material do not touch the inner surfaces, front cover of the CM-500/400/300 during cutting. Such contact may not only damage the material, but could also make normal material advancing impossible and cause the material to slip.
Is the material being cut blocked at some position?	<p>If the front edge of the material you are working with is at an angle, cut off the odd-shaped part to make it straight, then align it so that it is parallel with the grit roller.</p> <p>If the material is fed for a long distance, the material will be less likely to slip out of alignment if the pinch rollers are moved inward slightly (5 to 25 mm).</p> <p>When a roll material is loaded, use the display menu "AREA" function to feed a material by the length to be used (ensure a small margin by setting a length that is about 0.1 m longer than the cutting data), make sure the pinch rollers are still in contact with the material (not off the left or right edges, or on the edges), and then cut.</p> <p>If the material is pulled while cutting it is more likely that material misalignment and motor errors will occur.</p>

Cutting stops partway through

Does material strike the front cover during cutting?	If the edge of the material strikes the front cover, causing it to open, the message "CLOSE COVER" appears on the display and cutting pauses. Close the cover to resume cutting.
--	--

11-2 Error Messages

An error message will appear if incoming data has any of the errors listed in table. Since the error is shown in the display for informational purposes, the data transfer continues and you are allowed to perform the next operation.

To get the error message to go away, press the **(ENTER)** key.

Note that even though the error message is no longer displayed after you press the **(ENTER)** key, the CM-500/400/300 will retain in memory the fact that the error occurred. To clear the error internally, you can give the default instruction, IN; or the error code output instruction, OE. (The error can be cleared by turning the power off.)

The error messages and their meanings are as follows:

Error message	Meaning
Er1:Command Not Recognized	Appears if an instruction that the CM-500/400/300 cannot interpret is sent. This error is generated if an instruction from the "mode2" set is sent when the unit has been set to recognize "mode1," or viceversa. Change the setting for the recognized instruction set, using the control panel, and this error should no longer occur.
Er2:Wrong Number of Parameters	Appears if the number of parameters differs from the permissible number.
Er3:Out of Parameter range	Appears if the value specified for a parameter is out of the permissible range.
Er5:Unknown Character Set	Appears if an unusable character is specified.
Er10:Output Request Overlap	Appears if an output instruction is sent from the computer during execution of a previous output instruction. More precisely, there is a certain amount of delay between the moment an output instruction is given and the instant actual output begins. This error message appears if the new output request arrives during this delay time. (The delay time can be set using the [ESC].M instruction.)
Er11:Command Not Recognized	Appears if a device control instruction that the CM-500/400/300 cannot interpret is sent.
Er12:Wrong Parameter	Appears if an invalid parameter has been specified for a device control instruction.
Er13:Out of Parameter range	Appears if the value for a device control instruction parameter exceeds the permissible limit.
Er14:Termination Error	Appears if the number of parameters for a device control instruction is more than that permissible.
Er15:Framing/ Parity Error	Appears if a framing error, parity error, or overrun error occurs at the time of data reception.(There is a problem with one of these settings: Baud Rate, Parity, Stop Bits, or Data Bits. The protocol settings for the CM-500/400/300 must be made correctly in order to match the settings your computer is set to use.)
Er16:Buffer Overflow	Appears if the I/O buffer has overflowed.(There is a problem with the connecting cable, or the settings for Handshaking. Make sure you are using a cable appropriate for the computer being used. Also, check that the setting for Handshaking is correct.)
Er18: Indeterminate	Appears if the I/O buffer has overflowed.(There is a problem with the connecting cable, or the settings for Handshaking. Make sure you are using a cable appropriate for the computer being used. Also, check that the setting for Handshaking is correct.)

12 Instruction Support Chart

A "CAMM-GL III Programmer's Manual" is available for separate purchase for those wishing to create their own programs for this machine. For further information, please contact your authorized Roland dealer or service center.

The list uses marks, each of which means:

- : Compatible
- × : Incompatible
- : Ignored

mode 1

Instruction	Compatibility	Instruction	Compatibility	Instruction	Compatibility	Instruction	Compatibility	Instruction	Compatibility
H	○	D	○	M	○	I	○	R	○
L	○	B	○	X	○	P	○	S	○
Q	○	N	○	C	○	E	○	A	○
G	○	K	○	T	○	^	○		

mode 2

Instruction	Compatibility	Instruction	Compatibility	Instruction	Compatibility	Instruction	Compatibility	Instruction	Compatibility
AA	○	AR	○	CA	○	CI	○	CP	○
CS	○	DF	○	DI	○	DR	○	DT	○
EA	○	ER	○	EW	○	FT	○	IM	○
IN	○	IP	○	IW	○	LB	○	LT	○
OA	○	OC	○	OE	○	OF	○	OH	○
OI	○	OO	○	OP	○	OS	○	OW	○
PA	○	PD	○	PR	○	PT	○	PU	○
RA	○	RR	○	SA	○	SC	○	SI	○
SL	○	SM	○	SR	○	SS	○	SP	○
TL	○	UC	○	VS	○	WD	○	WG	○
XT	○	YT	○						

Instruction in mode 1 and mode 2

Instruction	Compatibility	Instruction	Compatibility	Instruction	Compatibility	Instruction	Compatibility
!FS	○	!NR	○	!PG	○	!ST	○

Device control instruction

Handshake instructions

Instruction	Compatibility	Instruction	Compatibility	Instruction	Compatibility	Instruction	Compatibility	Instruction	Compatibility
ESC.B	○	ESC.M	○	ESC.N	○	ESC.H	○	ESC.I	○
ESC.@	○	ESC.O	○	ESC.E	○	ESC.L	○		

About instructions

Instruction	Compatibility	Instruction	Compatibility	Instruction	Compatibility
ESC.J	○	ESC.K	○	ESC.R	○

13 Character Sets

Specifications

		CM-500	CM-400	CM-300
Mechanism		Media-movement method		
Driving method		Digital control servo motor		
Maximum cutting area		Width: 1195 mm (47") Length: 24998 mm (984-1/2")	Width: 1000 mm (39") Length: 24998 mm (984-1/2")	Width: 737 mm (29") Length: 24998 mm (984-1/2")
Acceptable media widths		Min. 90 mm (3-1/2") / Max. 1372 mm (54")	Min. 90 mm (3-1/2") / Max. 1178 mm (46")	Min. 50 mm (2") / Max. 915 mm (36") (50—540 mm (2"—21") , 582—915 mm (23"—36"))
Width of material that can be cut off		0—1270 mm (0"—50")	0—1067 mm (0"—42")	0—812 mm (0"—32")
Acceptable paper widths		Min. 90 mm (3-1/2") / Max. 1372 mm (54")	Min. 90 mm (3-1/2") / Max. 1178 mm (46")	Min. 50 mm (2") / Max. 915 mm (36") (50—540 mm (2"—21") , 582—915 mm (23"—36"))
Acceptable paper types		High-quality paper		
Tools		Cutters: Special cutter for CAMM-1 series Pens: Water-based fiber-tipped pens, and Thick water-based fiber-tipped pens (options)		
Max. cutting speed		During cutting: 850 mm/sec. (in all directions) During tool-up: 1202 mm/sec. (in 45° direction)		
Cutting speed		10—850 mm/sec. (in increments of 10 mm/sec.)		
Blade force		20—350 gf (in increments of 10 gf)		
Mechanical resolution		0.0125 mm/step (*0.000492"/step)		
Software resolution		0.025 mm/step (0.000984"/step)		
Distance accuracy		Error of less than +/- 0.2% of distance traveled, or 0.1mm (0.00394"), whichever is greater		
Repetition accuracy		0.1 mm or less (excluding stretching/contraction of the material) Range for assured repetition accuracy (*) For materials with a width exceeding 610 mm (24"): Length 4,000 mm (157-7/16") (CM-500/400 only) For materials with a width of 610 mm (24") or less : Length 8,000 mm (315-15/16")		
Interface		Parallel (Centronics compatible), Serial (RS-232C)		
Buffer size		2 MB (1.3 MB for replot buffer)		
Instruction system		CAMM-GLIII (mode1 and mode2)		
Switches		Power switch, Pen force slider		
Control switches		MENU, ENTER, TEST, SETUP, PAUSE, SHEET CUT, (◀), (▶), (▲), (▼)		
LED		POWER LED, SETUP LED, PAUSE LED		
Display		Liquid crystal display unit: 16-character by 2 lines		
Power consumption		1.0 A/117V, 0.5A/220-230V, 0.5A/230-240V		
Acoustic noise level		Cutting mode: under 62dB (A) Standby mode: under 40dB (A) (According to ISO 7779)		
Dimensions	Main unit	1586 mm (W) x 286 mm (D) x 281 mm (H) (62-1/2" (W) x 11-5/16" (D) x 11-1/8" (H))	1391 mm (W) x 286 mm (D) x 281 mm (H) (54-13/16" (W) x 11-5/16" (D) x 11-1/8" (H))	1128 mm (W) x 286 mm (D) x 281 mm (H) (44-7/16" (W) x 11-13/16" (D) x 11-5/16" (H))
	With stand	1586 mm (W) x 756 mm (D) x 1142 mm (H) (62-1/2" (W) x 29-13/16" (D) x 44-15/16" (H))	1391 mm (W) x 756 mm (D) x 1142 mm (H) (54-13/16" (W) x 29-13/16" (D) x 44-15/16" (H))	1128 mm (W) x 756 mm (D) x 1142 mm (H) (44-7/16" (W) x 29-13/16" (D) x 44-15/16" (H))
Weight	Main unit	41 kg (90.4 lb.)	35 kg (77.2 lb.)	27 kg (59.5 lb.)
	With stand	67.5 kg (148.8 lb.)	60 kg (132.3 lb.)	50 kg (110.2 lb.)
Operating temperature		5—40°C (41—104°F)		
Operating humidity		35—80% (non-condensing)		
Accessories		Power cord x 1, Blade holder (XD-CH2) x 1, Blade (ZEC-U5025) x 1, Test-use water based fiber tipped pen x 1, Test-use sheet x 1, Test-use application tape x 1, Tweezers x 1, Replacement blade for separating knife x 1, CAMM-1 DRIVER for windows® 95 x 1, User's manual x 1		

For items indicates by an asterisk "*", please see the next page.

(*) The following conditions must be satisfied:

- Material type: 3M Scotchcal Mastercut Film, ARLON Series 2100
- Special stand (a roll material must be set at the rear and on the inner sheet hanger)
- Side margins: 25 mm (1") or more for both the left and right margins
- Front margin: 25 mm (1") or more
(After loading the material, using the display menu to select "EDGE" as the material type automatically sets a front margin of 25 mm (1").)
- Use of the display menu's "AREA" function to perform feed of the material length plus 0.2 m and set the material correctly
- Cutting of the following data one time

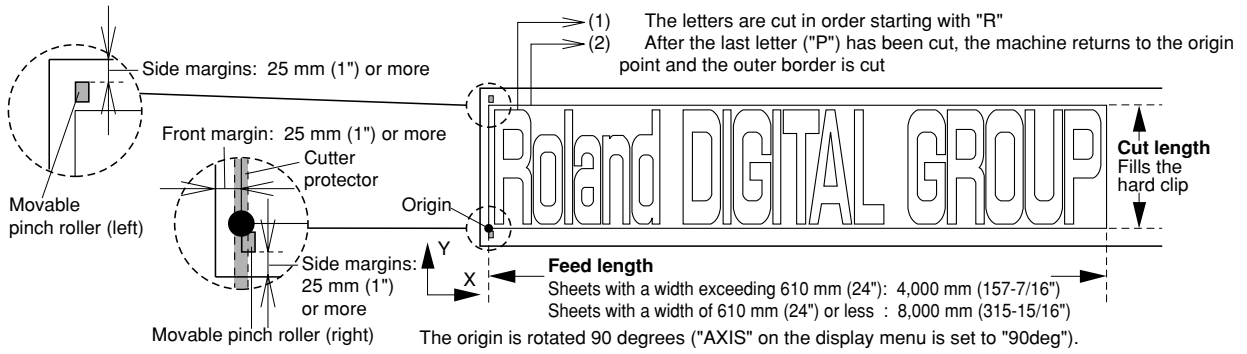

Interface specifications

Parallel

Standard	In compliance with the specifications of Centronics
Input signals	$\overline{\text{STROBE}}$ (1 BIT), DATA (8 BITS)
Output signals	BUSY (1 BIT), $\overline{\text{ACK}}$ (1 BIT)
Level of input/output signals	TTL level
Transmission method	Asynchronous

Serial

Standard	RS-232C specifications
Transmission method	Asynchronous, duplex data transmission
Transmission speed	2400, 4800, 9600, 19200 (Selected using panel keys.)
Parity check	Odd, Even, or None (Selected using panel keys.)
Data bits	7 or 8 bits (Selected using panel keys.)
Stop bits	1 or 2 bits (Selected using panel keys.)
Handshake	DTR or XON/XOFF (Selected using panel keys.)

Parallel connector (in compliance with specifications of Centronics)

Signal number	Terminal number	Signal number	Pin Connection
NC	36	18	HIGH**
HIGH*	35	17	GND
NC	34	16	GND
GND	33	15	NC
HIGH*	32	14	NC
NC	31	13	HIGH*
GND	30	12	GND
	29	11	BUSY
	28	10	$\overline{\text{ACK}}$
	27	9	D7
	26	8	D6
	25	7	D5
	24	6	D4
	23	5	D3
	22	4	D2
	21	3	D1
	20	2	D0
19	1	$\overline{\text{STROBE}}$	

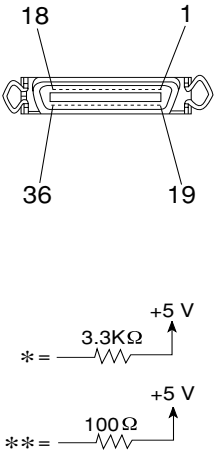

Serial connector (RS-232C)

Signal number	Terminal number	Signal number	Pin Connection
NC	25	13	NC
NC	24	12	NC
NC	23	11	NC
NC	22	10	NC
NC	21	9	NC
DTR	20	8	NC
NC	19	7	SG
NC	18	6	DSR
NC	17	5	CTS
NC	16	4	RTS
NC	15	3	RXD
NC	14	2	TXD
		1	FG

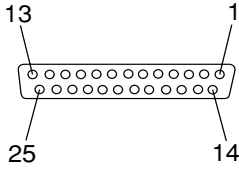

Please read this agreement carefully before opening the sealed package or the sealed disk package

Opening the sealed package or sealed disk package implies your acceptance of the terms and conditions of this agreement. If you do NOT accept this agreement, retain the package UNOPENED. (This product is just one of included items. Please be aware that any amount of the purchase price will not be refunded for return of this product as a single item, regardless of whether the package is opened or unopened.) The enclosed Roland product is a single user version.

Roland License Agreement

Roland DG Corporation ("Roland") grants you a non-assignable and non-exclusive right to use the COMPUTER PROGRAMS in this package ("Software") under this agreement with the following terms and conditions.

- 1. Coming into Force**

This agreement comes into force when you purchase and open the sealed package or sealed disk package.
The effective date of this agreement is the date when you open the sealed package or sealed disk package.
- 2. Property**

Copyright and property of this Software, logo, name, manual and all literature for this Software belong to Roland and its licensor.

The followings are prohibited :

 - (1) Unauthorized copying the Software or any of its support file, program module or literature.
 - (2) Reverse engineering, disassembling, decompiling or any other attempt to discover the source code of the Software.
- 3. Bounds of License**

Roland does not grant you to sub-license, rent, assign or transfer the right granted under this agreement nor the Software itself (including the accompanying items) to any third party.
You may not provide use of the Software through time-sharing service and/or network system to any third party who is not individually licensed to use this Software.

You may use the Software by one person with using a single computer in which the Software is installed.
- 4. Reproduction**

You may make one copy of the Software only for back-up purpose. The property of the copied Software belongs to Roland.
You may install the Software into the hard disk of a single computer.
- 5. Cancellation**

Roland retains the right to terminate this agreement without notice immediately when any of followings occurs :

 - (1) When you violate any article of this agreement.
 - (2) When you make any serious breach of faith regarding this agreement.
- 6. Limitations on Liability**

Roland may change the specifications of this Software or its material without notice.

Roland shall not be liable for any damage that may caused by the use of the Software or by exercise of the right licensed by this agreement.
- 7. Governing Law**

This agreement is governed by the laws of Japan, and the parties shall submit to the exclusive jurisdiction of the Japanese Court.